



# **Sweepway**

**The power sweep unloading system**

**Owners Installation & Operation Manual**

**Sukup Manufacturing Company  
1555 - 255th Street P.O. Box 677  
Sheffield, Iowa 50475  
Phone 641 - 892 - 4222  
Fax 641 - 892 - 4629**



## Sukup Manufacturing Company

PO Box 677 Sheffield, IA 50475

Phone: 641-892-4222 Fax: 641-892-4629

E-mail: [Info@sukup.com](mailto:Info@sukup.com) Visit us at: [www.sukup.com](http://www.sukup.com)

---

### LIMITED WARRANTY

**SUKUP MANUFACTURING COMPANY (Sukup)** warrants to original retail purchaser that within time limits set forth, new equipment shall be free from defects in material and workmanship. A part will not be considered defective if it substantially fulfills performance specifications. Should any part prove defective within the warranty period, the part will be replaced without charge F.O.B. Sukup Mfg. Co., Sheffield, Iowa or Distribution Centers - Arcola, Illinois; Aurora, Nebraska; Defiance, Ohio; Jonesboro, Arkansas; Kansas City, Missouri; Watertown, South Dakota. To obtain warranty, a copy of original invoice is required, see reverse side.

THE FOREGOING LIMITED WARRANTY IS EXCLUSIVE AND IN LIEU OF ALL OTHER WARRANTIES OF MERCHANTABILITY, FITNESS OR PURPOSE AND OF ANY OTHER TYPE, WHETHER EXPRESSED OR IMPLIED. Sukup neither assumes nor authorizes anyone to assume for it any other obligation or liability in connection with said part, and will not be liable for incidental or consequential damages. THE REMEDIES STATED HEREIN SHALL BE THE EXCLUSIVE REMEDIES AVAILABLE UNDER THIS LIMITED WARRANTY.

Sukup reserves the right to change specifications, add improvements or discontinue manufacture of any of its equipment without notice or obligation to purchasers of its equipment. This warranty gives you specific legal rights. You may also have other rights which vary according to state or province.

**WARRANTY EXCLUSIONS** - Labor, transportation, or any cost related to a service call is not provided by Sukup. This Limited Warranty does not apply to damage resulting from misuse, neglect, normal wear, accident or improper installation or maintenance. ITEMS NOT MANUFACTURED BY SUKUP (i.e. Tires, Belts, Motors, etc.) ARE COVERED UNDER WARRANTIES OF THEIR RESPECTIVE MANUFACTURERS AND ARE EXCLUDE FROM COVERAGE UNDER THE SUKUP WARRANTY. Since the down augers are so critical to the successful operation of the stirring machine, Sukup Mfg. will not warranty any machines unless they are equipped with Sukup down augers.

**BASIC WARRANTY** - All Sukup manufactured products are warranted for one year from date of purchase.

**EXTENDED STIRRING MACHINE WARRANTY** - Sukup warrants Stirring Machines for two years from date of purchase.

**EXTENDED STIRRING AUGER WARRANTY** - Stirring Augers are warranted for two years from date of purchase. Must return top 18" of down auger to obtain credit.

**EXTENDED FASTDRY AND AUTO DRY WARRANTY** - Sukup warrants FastDry and Auto Dry for two years from date of purchase.

**EXTENDED FAN WARRANTY** - Sukup warrants fans for two years from date of purchase.

**EXTENDED GRAIN DRYER WARRANTY** - Sukup warrants grain dryers for two years from date of purchase.

**EXTENDED HEATER CIRCUIT BOARD WARRANTY** - Sukup warrants heater circuit boards for three years from date of purchase.

**ELECTRIC MOTOR WARRANTY** - The manufacturers of electric motors warranty their motors through authorized service centers. Contact motor manufacturer for nearest location. If motor warranty is refused by a service center based upon date of manufacture, use the following procedure: Have the motor repair shop fill out the warranty report form as if they were providing warranty service. State on the report the reason for the refusal. Send the report, motor nameplate, and proof of purchase date to Sukup. If electric motor warranty is not satisfactorily handled by motor service center, contact Sukup for assistance. Warranty may also be obtained by returning motor to Sukup Mfg. Co. or Distribution Centers with prior authorization. **NOTE:** Sukup will not be responsible for unauthorized motor replacement or repair.

**WARRANTY CERTIFICATION** - Warranty registration card should be mailed within two weeks of product delivery to certify warranty coverage.

**UNAPPROVED PARTS OR MODIFICATION** - All obligations of Sukup under this warranty are terminated if: unapproved parts such as stirring augers are used, or if equipment is modified or altered in any way not approved by Sukup.

# INTRODUCTION

Congratulations on your purchase of the Sweepway Unload system. Your Sukup Sweepway is designed, built and tested to assure highest quality and maximum life.

Read and study operator's manual carefully to learn how to safely service and operate your machine. Failure to do so could cause personal injury or equipment damage.

For your convenience fill in the following information:

Sweepway: 6" \_\_\_\_\_ 8" \_\_\_\_\_ 10" \_\_\_\_\_ Bin Diameter:

With Horizontal Unload: Single Motor Drive \_\_\_\_\_ PTO Drive \_\_\_\_\_

With Vertical Unload: 16' \_\_\_\_\_ 20' \_\_\_\_\_  
2 Motor Drive (2 Motor Top \_\_\_\_\_ 2 Motor Bottom \_\_\_\_\_) Single Motor Drive \_\_\_\_\_ PTO Drive \_\_\_\_\_

25 Degree Incline: 6" to 8" \_\_\_\_\_ 8" to 10" \_\_\_\_\_

Date of Purchase: \_\_\_\_\_

---

## CONTENTS

<b>Warranty</b>	<b>2</b>
<b>Introduction/Contents</b>	<b>3</b>
<b>Safety</b>	<b>4-6</b>
<b>Preparation</b>	<b>7</b>
<b>Installation</b>	<b>8-11</b>
<b>Instructions for Carrier Wheel Assembly</b>	<b>12</b>
<b>Horizontal Powerheads &amp; Scraper Installation</b>	<b>13-19</b>
<b>Basic Vertical Auger</b>	<b>20-21</b>
<b>Vertical Flighting, Shafts</b>	<b>22</b>
<b>Top Drive Assembly</b>	<b>23-25</b>
<b>Vertical Boot Options</b>	<b>26-29</b>
<b>5' Incline</b>	<b>30-32</b>
<b>Operating Instructions</b>	<b>33-34</b>
<b>Parts Assemblies</b>	<b>35-47</b>

# SWEEPWAY SAFETY SECTION

## RECOGNIZE SAFETY ALERT SYMBOL



The above safety-alert symbol means "Attention! Be Alert! Your personal safety is involved!" This symbol draws your attention to important instructions concerning your personal safety. Read the message carefully to avoid personal injury or death.

---

### FOLLOW MACHINE SAFETY SIGNS & MESSAGES

Observe safe operating practices. Carefully read this manual and all safety signs on your equipment. Safety signs must be kept in good condition. Replace missing or damaged safety decals or shields; available from Sukup Manufacturing Co., Box 677, Sheffield, Iowa 50475 at no charge.

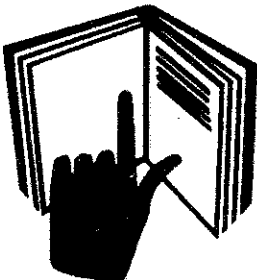

Learn how to use controls and operate equipment. Do not let anyone operate unit (especially youth) without thorough training of basic operating and safety procedures.

Make no unauthorized modifications to equipment. Modifications may endanger function and/or safety of unit. Periodically check all mechanical and electrical components. Keep unit in good working condition.

---

### EMERGENCIES - KNOW WHAT TO DO

Have emergency numbers near your telephone:

- For doctors:
- Emergency medical squad:
- Ambulance service:
- Hospital:
- Fire department:

Have written directions to your location:

### DANGER!

Never enter bin unless all power is locked off and another person present.

Rotating augers can kill or dismember!



**NEVER, NEVER, clean out bin with augers running!**

When bin is nearly empty, sweep (floor) augers travel at increasing speed, just turning around can give augers time enough to trap you. Exposed auger in sump can cause serious injury if stepped or fallen into.

Failure to follow the above precautions may cause serious injury or death.

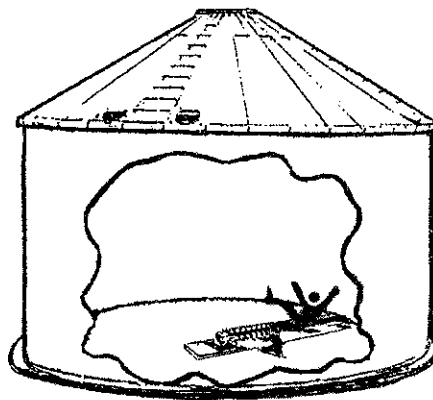

---

### NEVER ENTER BIN

 **DANGER:** Never enter bin, unless all power is **locked off** and another person is present.

Flowing grain may trap and suffocate. If you enter a bin of flowing grain you can be completely submerged in



grain in about 8 seconds.

**! CAUTION:**

To avoid electrocution, all equipment must be properly wired and grounded according to electrical codes. Have unit wired by qualified electrician.



Have your electrician install a main power disconnect switch capable of being locked only in the OFF position. Mark disconnect clearly as to the equipment it operates.

**Service Disconnect**

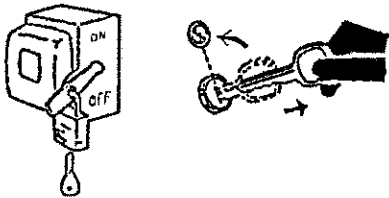

Always LOCK OFF main power disconnect switch whenever equipment is not in use or when servicing unit.

To LOCK OFF PTO driven units, shut off tractor, disconnect PTO shaft, and remove ignition key from tractor.

**! DANGER:**

When servicing equipment, never enter bin, unless all power is locked out and another person is present. Always LOCK OFF all power and always check with voltage meter before servicing.

Failure to do so may cause serious injury or death.

**! CAUTION:**

Metal edges are sharp. To avoid injury wear protective clothing and handle equipment and parts with care.

Failure to do so may cause serious injury or death.

**! CAUTION:** Maintain secure hand and foot hold when climbing on bin. Metal is slippery when wet. Never carry items while climbing on bin to avoid falls.

Failure to do so may cause serious injury or death.

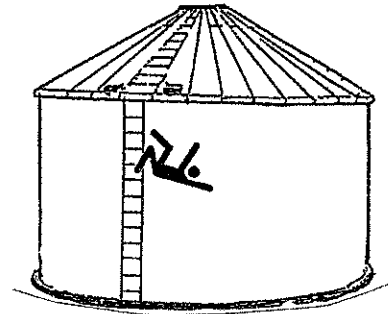

**! WARNING: KEEP CLEAR OF ALL MOVING PARTS.**

Keep people (ESPECIALLY YOUTH) away from equipment, particularly during operation.



Keep away from all moving parts. Keep all shields in place. SHUT OFF AND LOCK OUT all power before servicing.

Failure to follow the above precautions may cause serious injury or death.

**! DANGER:** Keep away from rotating drive line. Entanglement can cause serious injury or death. Keep all drive shields and guards in place and in good condition. Tractor PTO yoke must be locked in place. Adjust tractor hitch to proper dimensions.



## SWEEPWAY SAFETY

Safety decals #1 - #5 should be mounted on your equipment as shown on this page. Safety decals #1 and #4 must be mounted during installation. Make sure location area for decal is free from grease, oil and dirt. Remove backing from decal and place in proper position.

**Important:** If suggested locations are not clearly visible, place safety decals in more suitable area. Never cover up any existing safety decals in more suitable area. Never cover up any existing safety decals.

Please check that all decals and shields are in place according to these drawings and in good legible condition. To order replacement decals and shields (no charge) contact your dealer or Sukup Manufacturing Co., Box 677, Sheffield, IA 50475.

### 1. WARNING DECAL - L0281 - Safe operation.

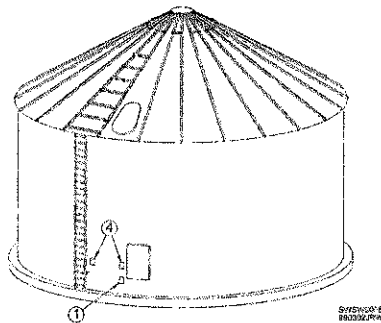
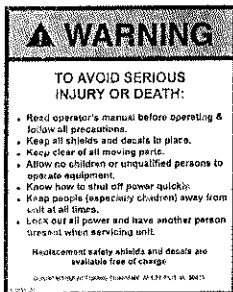

### 2. DANGER DECAL - L0271- Replace missing shield.

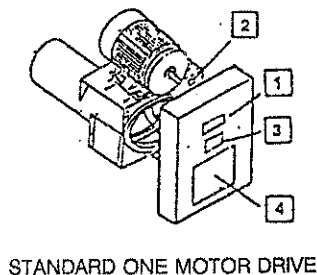

STANDARD ONE MOTOR DRIVE

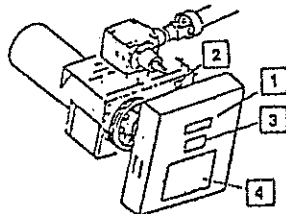

POWER-TAKE-OFF DRIVE

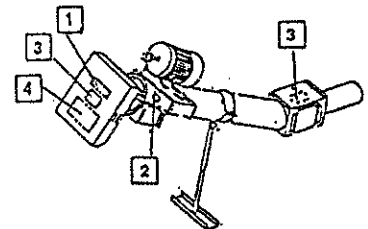

INCLINED HORIZONTAL DRIVE

### VERTICAL BOOT OPTIONS

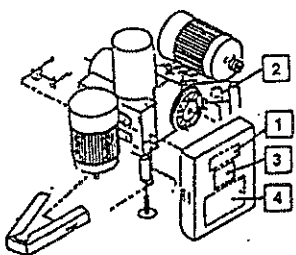

TWO MOTOR DRIVE (STANDARD)

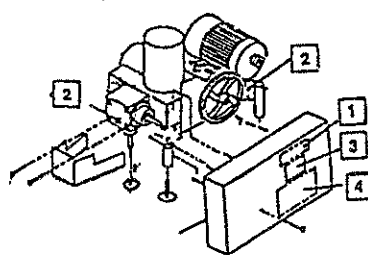

ONE MOTOR DRIVE OPTION

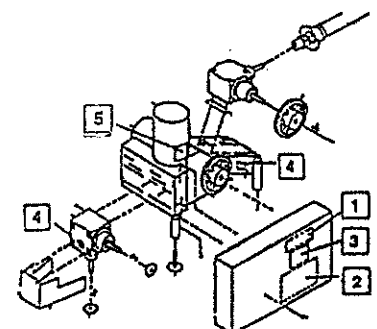

PTO DRIVE OPTION

### 3. WARNING DECAL - L0284 - Keep away from moving parts.



### 4. DANGER DECAL - L0301 - Mount this decal on bin sheet near door handle and all other entry points sor by ladder going to roof.



### 5. DANGER DECAL - L0250 - Keep away! Rotating drive line .



# PREPARATION

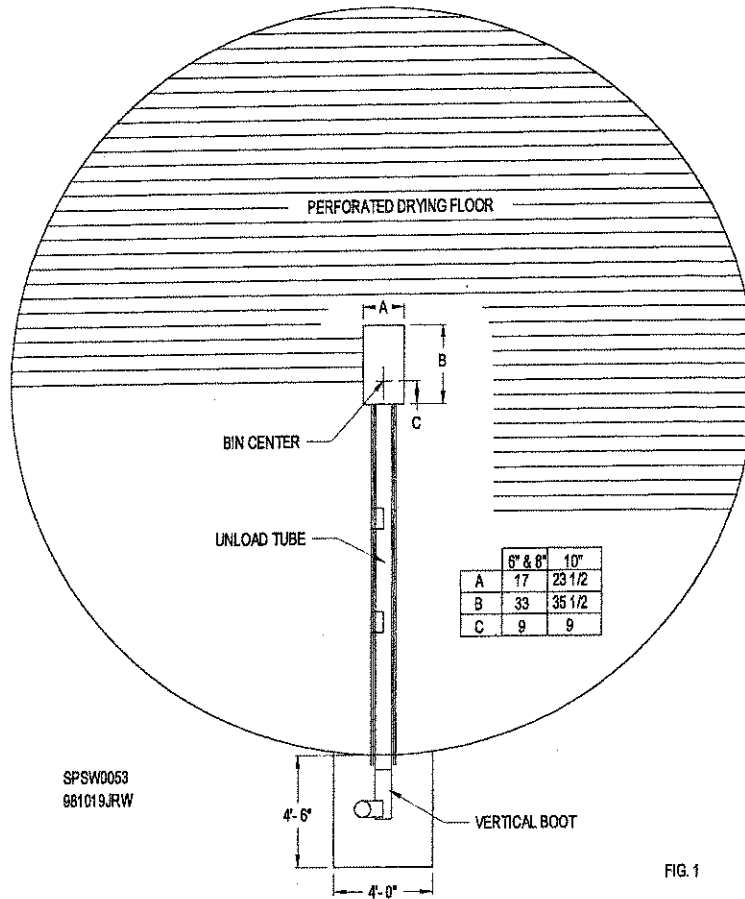

1. A. Determine side of bin from which you wish to unload. Unloading tube must have unobstructed path to center sump. Floor supports must run parallel to unloading tube; on existing systems, it may be necessary to re-install the floor. Fig. 1

B. Check floor height. The minimum plenum height required for installation of sweep is:

6" and 8"	12"
10"	13-1/4"

Maximum floor thickness is:

6" and 8"	2-3/4"
10"	1-3/4"

C. **IMPORTANT:** Floor flashing must be installed as shown in Fig. 2 to prevent excessive wear on the drive wheel. The sweep moves in a clockwise direction so check that flashing is overlaid so the sweep wheel "steps up".

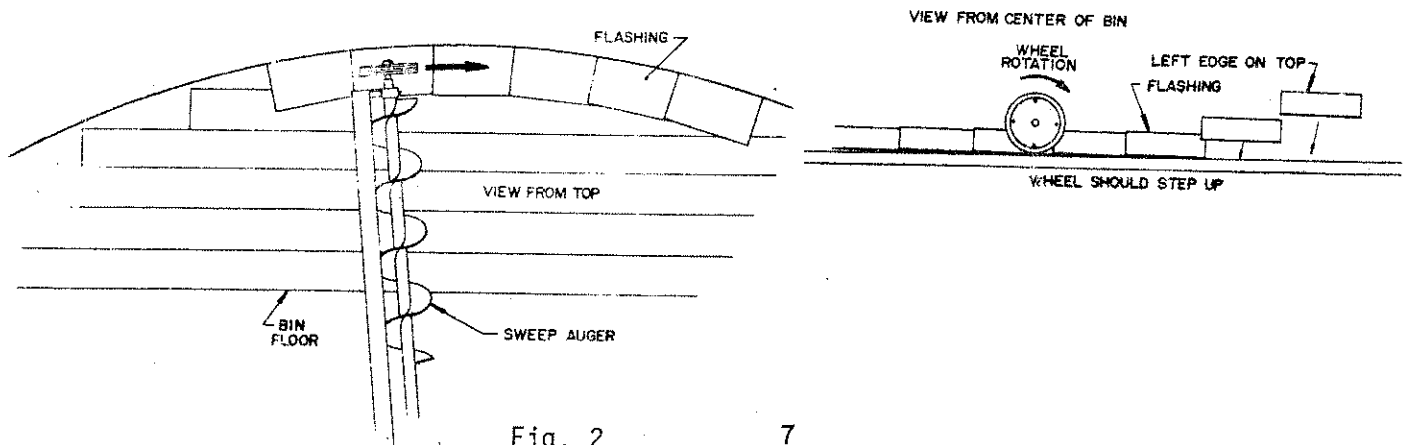

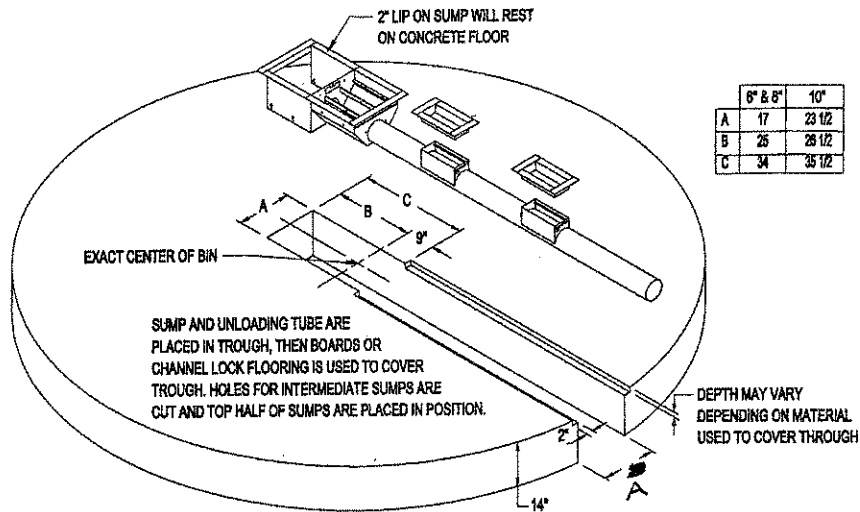

SPSW0030  
981018JRW

Fig. 3

**2. FOR CONCRETE TROUGH INSTALLATION:**

Sump and unloading tube are placed in trough, because of moving slide gates and pull rods, concrete CANNOT be poured over sweep tube. Cover trough with boards or channel lock flooring. NOTE: Center of TOP gearbox must be in exact center of bin. Fig. 3

3. A concrete pad, 4'6" x 4' measured from bin foundation, is required on sweeps with vertical. This pad should be poured below the level of concrete floor of bin, as shown in Fig. 4.

NOTE: Loosen threaded support leg in winter and re-tighten in spring.

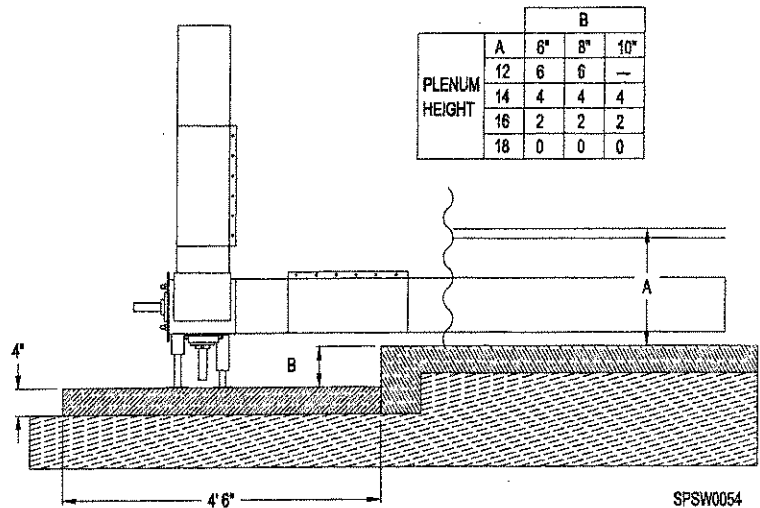

SPSW0054  
981023JRW

FIG. 4

**INSTALLATION**

Note: Instructions are written so that sweep can be installed in an existing system when the floor is arranged as shown in Fig. 1.

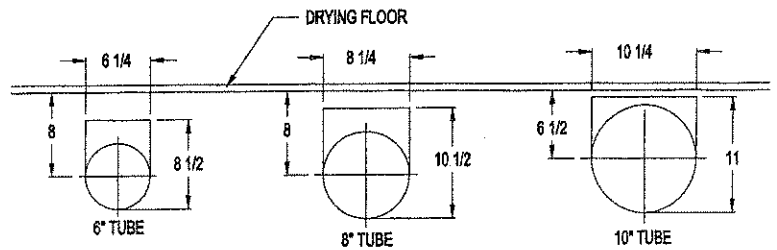

BIN WALL CUTOUT

Fig. 5

SPSW0031  
950803KR

1. Cut hole in bin at desired unloading location, with center of hole located (Specified distance shown in Fig. 5) from top of drying floor. Fig. 5. The size of the hole is as shown below:

- 6" Sweep, cut 6-1/4" x 8-1/2" hole
- 8" Sweep, cut 8-1/4" x 10-1/2" hole
- 10" Sweep, cut 10-1/4" x 11" hole

2. Locate center of bin. Center sump is positioned so that center of top gearbox is exact center of bin. Center sump must align with bin wall opening.

Position sump on top of bin floor. With spray paint, mark pattern around sump on floor. Cut appropriate size hole for sump. Fig. 1.



- Lower sump into hole with unloading sump towards bin wall opening. Fig. 6. Block up center sump at bottom using non-flammable material. Place extra floor supports around sump for additional support.

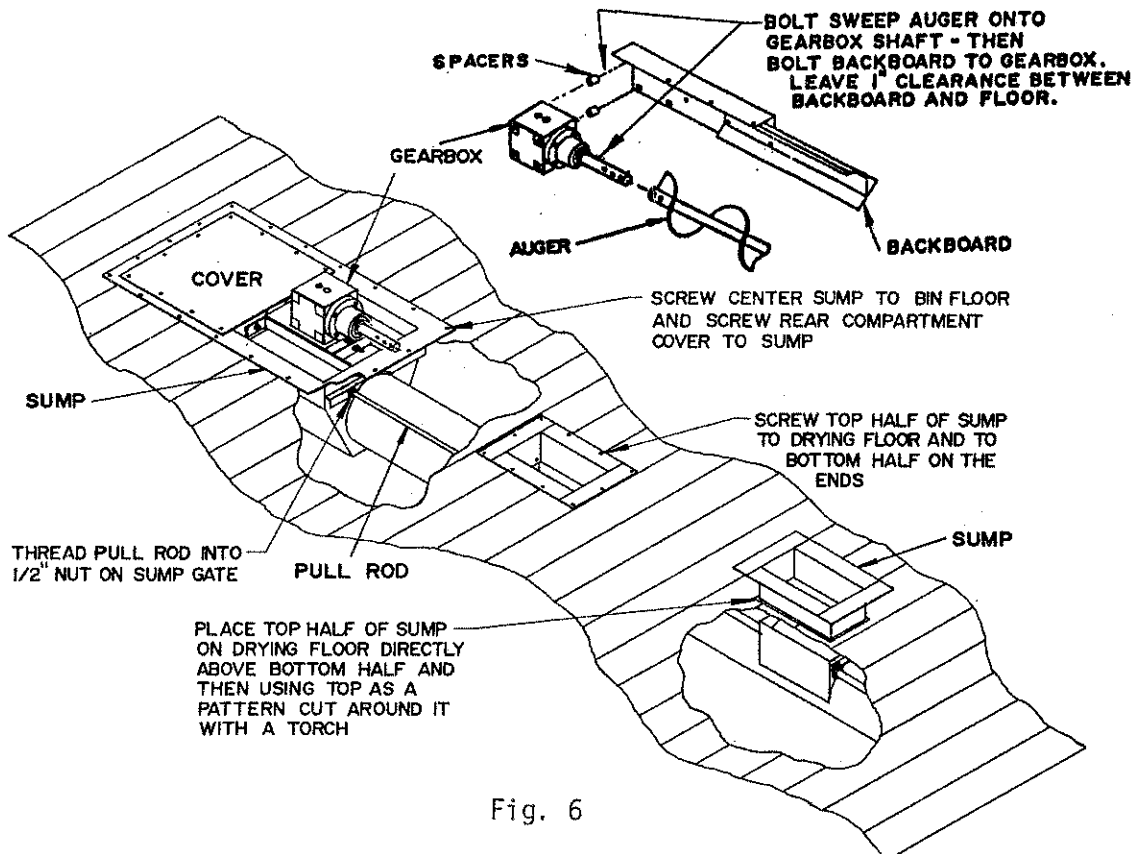

Fig. 6

- With unloading sumps on the **top left** side of tube, slide unloading tube through bin wall and **into sump**. Rotate tube so that intermediate sumps are directly upwards and bolt tabs welded on tube to sump through holes provided in sump. Fig. 6 and 7.
- Slide unloading auger, square end first, through unloading tube and over solid shaft in sump. Fig. 7 For units with low-boy extension, it may be advisable to drill and pin through unload auger and square shaft to prevent auger from pulling out when powerhead is detached. This is necessary only if powerhead is to be changed frequently.

*Note: In all installation instruction, right and left shall be as you face center of bin.*

- Slide bin collar over tube protruding from bin. Rotate bin collar so clutch rod and lock assembly hole is on the lower right side. Collar clamps will be horizontal. Mark clutch hole and cut through bin wall. Using metal screws, fasten bin collar to bin wall. Caulk around collar. Do not tighten bin collar clamps yet. Fig. 8
- Slide clutch rod through bin collar and into rear compartment of center sump. On 30' bins and larger, bolt clutch rod support clamp midway on unload tube, and slide clutch rod through support. Fig. 8 Attach clutch rod to clutch arm with 1/2" x 1-1/2" pin and hairpin clip. Fig. 7

Clutch is factory-set. However, check clutch that teeth engage and disengage properly. There should be approximately 1/4" clearance when clutch is disengaged. Fig. 7. Three dog clutch disc. may be moved by loosening bolts to allow adjustment.

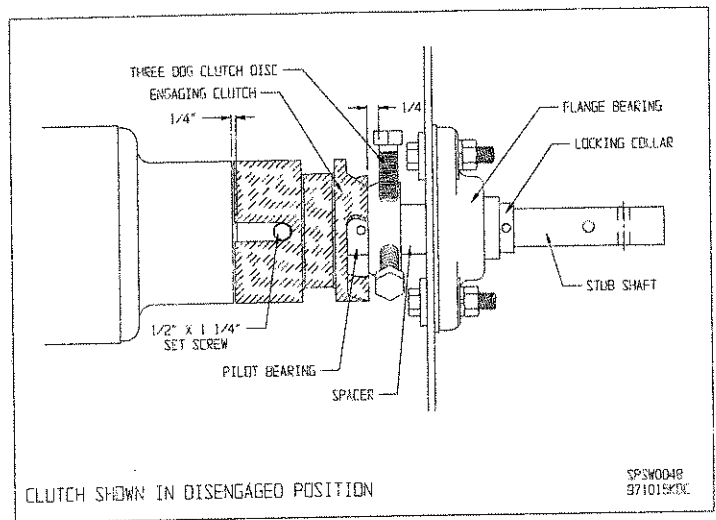
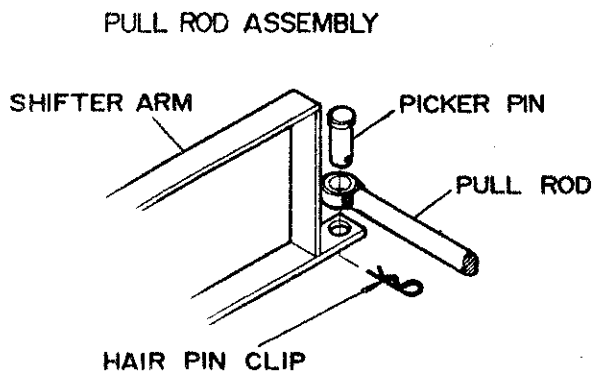
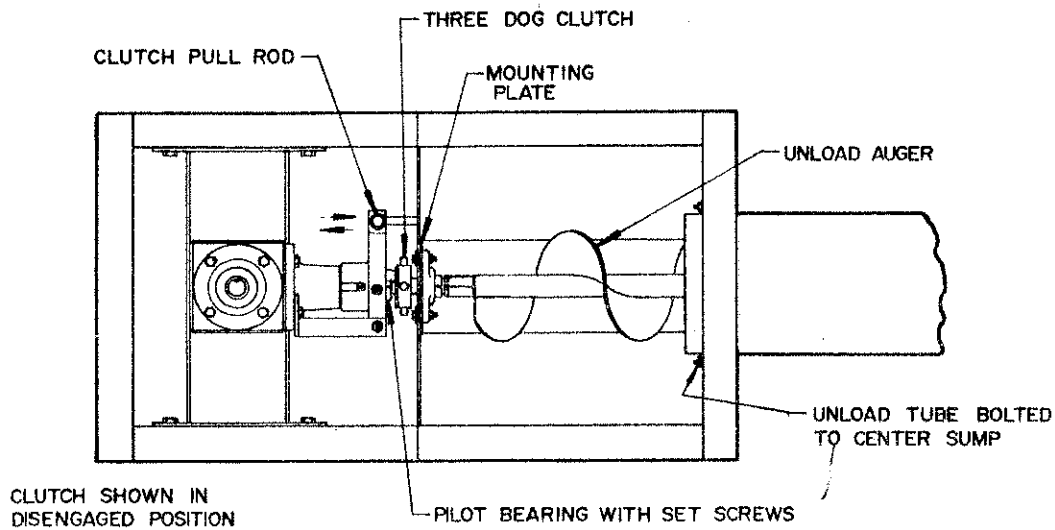
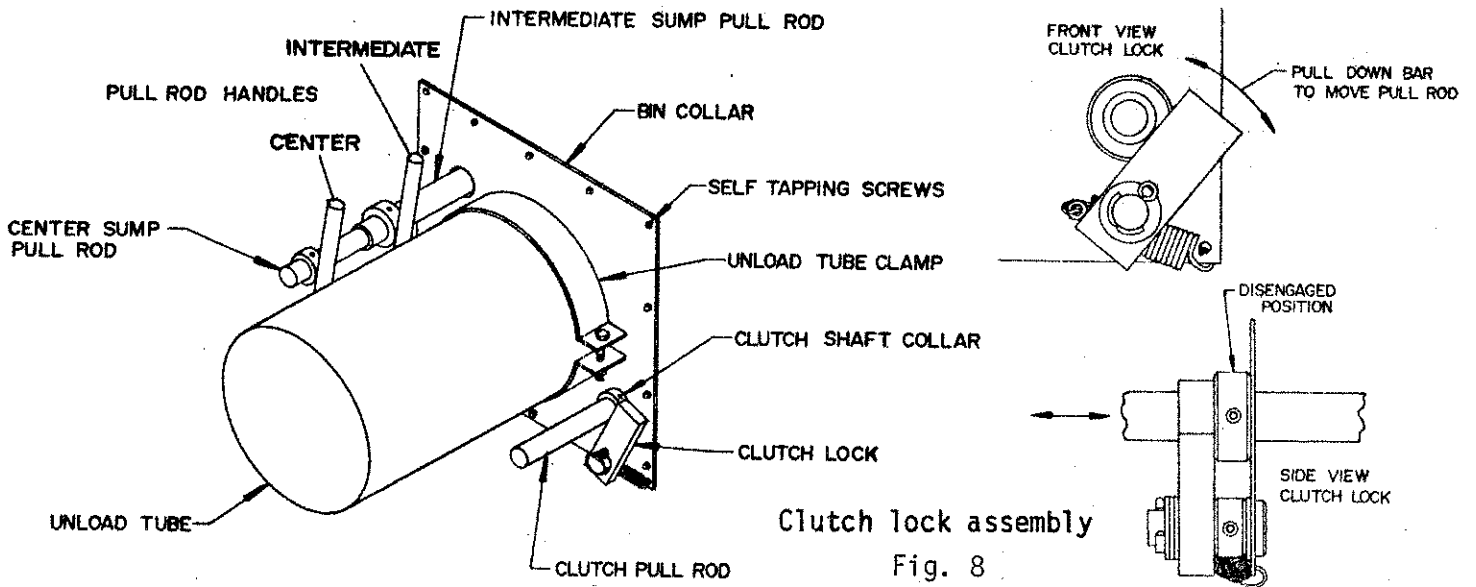

Fig. 7



8. Refer to Fig. 6. Locate sump hole positions directly above intermediate sumps on unloading tube. Place top half unloading sump on drying floor directly over sump on unloading tube, mark it, and cut with torch. Do this for each sump hole. Quantity of sumps vary with diameter of bin.
9. Reach through intermediate sump hole nearest the main center sump and guide center sump pull rod up to 1/2" nut welded to center sump slide. Fig. 6. Thread pull rod into nut until tight.
10. Slide 7/8" handle onto intermediate sump rod. Slide 1/2" handle over center sump pull rod. Tighten set screws. Peen ends of rods so handles cannot pull off. Check to see that all sumps open freely. Fig. 8.
11. Place top half unloading sumps through hole cut in drying floor and into bottom half sump on unloading tube. Secure flange to drying floor with metal screws. Secure top half sump to bottom half with two metal screws through end of sump. Fig. 6. Do this for each unloading sump.
12. With all unloading sumps in position, and all sump slides operating freely, tighten clamps on bin collar outside of bin. Fig. 8.
13. Slide 1" shaft collar onto pull rod with clutch disengaged (rod pushed in). Fig. 8. Push collar on all the way. Lift up on latch and slide shaft collar all the way against bin collar so that it is sandwiched between latch and bin collar. Tighten with set screws. When latch is lifted, clutch can be engaged (rod pulled out). Latch will keep clutch firmly disengaged as well as preventing accidental engaging of equipment. Fig. 8.



Clutch lock assembly

Fig. 8

14. a. Bring sweep auger and backboard into bin. Bolt sweep auger to gearbox shaft, using the two holes in gearbox shaft that allow sweep wheel to run as close to bin wall as possible, and still clear the sweep stop when it is in operating position. Position backboard bracket slots over bolt holes on right side of gearbox. Place spacers between backboard and gearbox. Bolt through bracket and spacers into gearbox. Tighten securely. Fig. 6.

**THERE SHOULD BE AT LEAST 1" CLEARANCE BETWEEN FLOOR AND BACKBOARD.**

**b. FOR SPLIT BACKBOARD ASSEMBLY (FOR 42' AND OVER:)**

1. Sukup recommends that only the inside sweep section be installed and operated for the first revolution around the bin, than the outside sweep be installed to complete unloading.
2. The bin should be swept in stages, beginning with the inside section, (it is recommended that the inner section be used first) than the outer section be added and remainder of bin be swept.



**Never enter bin while equipment is operating. Shut off complete system before adding outer section.**

After installing inside section, position inside section over top of intermediate sumps. Lay the outside section of sweep auger and backboard in line with the inside section, leaving 6" between sections for auger splice and channel iron spacer. When outside section of sweep auger and backboard are needed, unbolt sweep wheel from inside section. Line up the inside section with outside section. Bolt the two augers together with the 6" auger splice. Connect the two backboards together by inserting the 6" channel iron spacer between the two backboards and bolting together. Fig. 18.

Wear plates furnished at no charge for those who request them for split backboards.

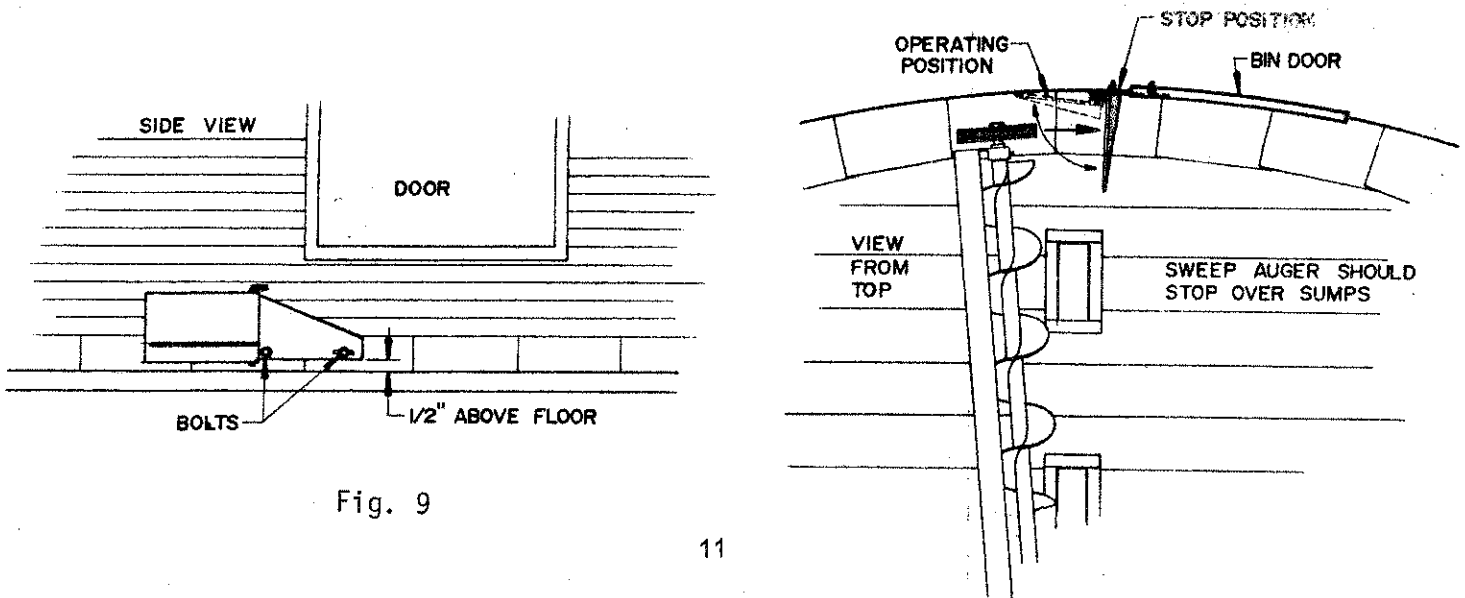
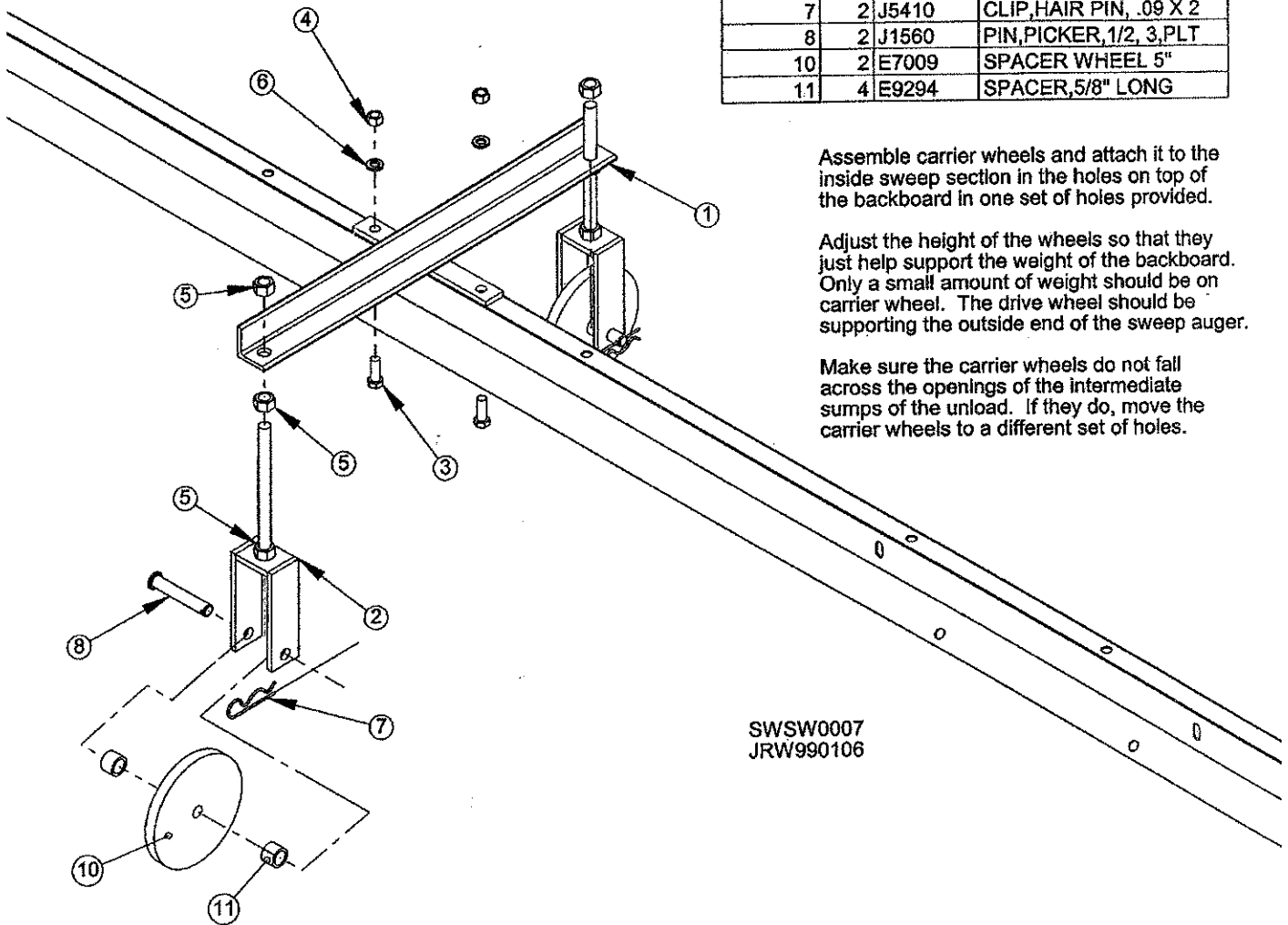

Fig. 9

# INSTRUCTIONS FOR CARRIER WHEEL ASSEMBLY

## E70191

ITEM NO.	QTY.	PART NO.	DESCRIPTION
1	1	E7019	SUPPORT WHL BKT
2	2	E7008	WHEEL YOKE
3	2	J0606	SCREW, 3/8 -16,1,PLT
4	2	J1020	NUT, HEX, 3/8-16,PLT
5	6	J1040	NUT, HEX, 1/2-13,PLT
6	2	J1205	WASHER, LOCK,3/8,PLT
7	2	J5410	CLIP,HAIR PIN, .09 X 2
8	2	J1560	PIN,PICKER,1/2, 3,PLT
10	2	E7009	SPACER WHEEL 5"
11	4	E9294	SPACER,5/8" LONG



Assemble carrier wheels and attach it to the inside sweep section in the holes on top of the backboard in one set of holes.

Adjust the height of the wheels so that they just help support the weight of the backboard. Only a small amount of weight should be on carrier wheel. The drive wheel should be supporting the outside end of the sweep auger.

Make sure the carrier wheels do not fall across the openings of the intermediate sumps of the unload. If they do, move the carrier wheels to a different set of holes.

SWSW0007  
JRW990106

**Do not use carrier wheels when using inside backboard section only.**

L0521

15. Bolt stop to bin wall so that the auger will be stopped over unloading sumps. It should be mounted near the door so that it can be positioned without entering bin. Fig. 9.

16. Fasten sump cover over rear compartment of main sump with metal screws. Fig. 6.

## HORIZONTAL POWERHEAD MOTOR DRIVE & PTO DRIVE

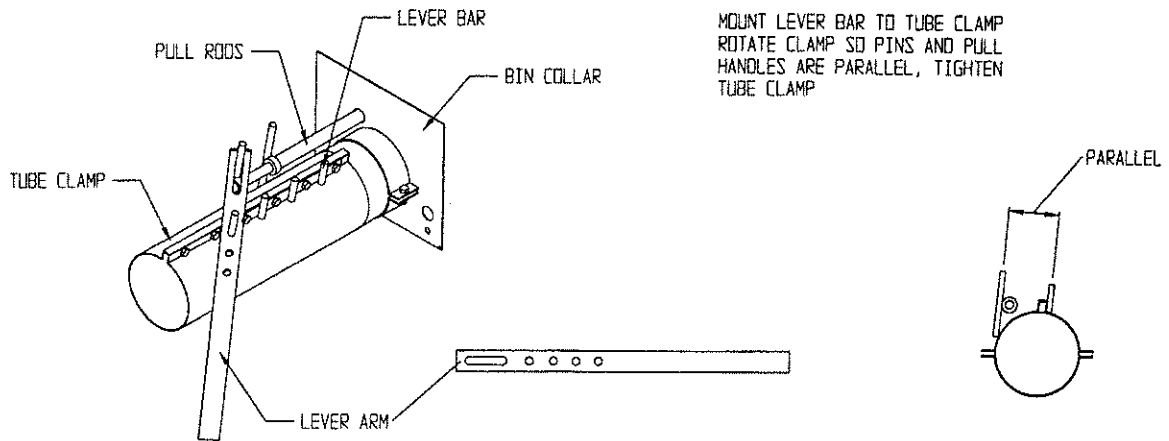

Fig. 10

SPSW0032  
950807KR

1. Slide connector sleeve onto unloading tube. Bolt lever bar to connector sleeve with 3/8" x 3" bolts, nuts, and lockwashers. Partially tighten bolts. FIG. 10
2. Remove safety shield from powerhead assembly. Slide powerhead tube into connector sleeve so unload auger shaft protrudes through flange bearing. Slide powerhead on completely so that it butts against unloading tube.
3. Rotate powerhead assembly to level position and tighten bolts on connector sleeve.
4. **IMPORTANT:** Slide locking collar over auger shaft protruding from unloading tube and lock onto flange bearing. Tighten set screw on locking collar.
5. **FOR MOTOR DRIVE ONLY; FIG. 11**
  - A. Mount 3.4" motor pulley onto motor shaft. Secure with key and set screw.
  - B. Mount motor onto motor mount plate with 3/8" x 1-1/2" bolts, nuts, lockwashers and flat washers.
  - C. Attach pulley to shaft extending from unloads tube. Place 1/4" key in slot on pulley and align with motor pulley. Tighten set screw.
  - D. Place belts provided on pulleys. Tension may be adjusted by tightening bolt on bottom motor mount plate.

### FOR PTO DRIVE ONLY: FIG. 12

- A. Mount 9" double groove "B" pulley onto gearbox shaft and secure with key & set screw.
  - B. Mount 9" double groove "B" pulley onto shaft extending from unload tube. Align pulley with gearbox pulley and secure with 1/4" key and set screw.
  - C. Place belts provided on pulleys. Tension may be adjusted by tightening bolt on bottom motor mount plate.
  - D. Mount PTO drive shaft onto other gearbox shaft and secure with 1/4" key and set screw.
6. Place safety shield over pulleys and tighten bolts. **KEEP SHIELD IN PLACE AT ALL TIMES!**

# Sweepway Backboard Scrapper Installation

Installation on new SWEEPWAY backboard with holes pre-punched.

Included in with the SWEEPWAY is the parts sack and scrappers for installing them with. The part numbers for the scrapper packages are as follows.

SCRAPPER PACKAGE		E5100	E5101	E5102	E5103	E5104	E5105	E5106	E5107
BIN SIZE		14-22'	23-28'	29-32'	33-39'	40-44'	45-50'	51-54'	55-62'
SCRAPPER 36"	E8420	2	3	4	5	4	5	6	7
SCRAPPER, SPLICE	E8425	0	0	0	0	2	2	2	2
HARDWEAR SACK #'S		E5100-01	E5101-01	E5102-01	E5103-01	E5102-01	E5103-01	E5106-01	E5107-01

## INSTALLATION FOR BINS LESS THAN 39' IN DIAMETER.

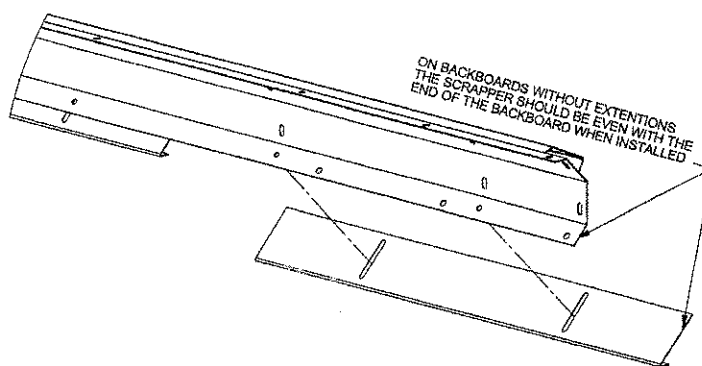

SWSW0012  
000711 JRW

1. Starting at the drive wheel end of the backboard. Take a scrapper and place it flat against the backside of the backboard with the bent lip towards the floor and away from the auger. Align the end of the backboard with the end of the scrapper. The slots in the scrapper should align with the holes in the bottom lip of the backboard.
2. Attach the scrapper to the backboard using the 5/16" x 1" bolts with the head of the bolt on the inside (auger side) of the backboard. Use the flat washer, lock washer and nut on the backside of the scrapper. Adjust the scrapper so they are spaced away from the floor at the desired distance wanted and tighten. **NOTE:** Sitting scrapper to low may limit forward travel of sweep auger and reduce unload capacity.
3. Continue attaching the scrappers on the backboard until they are all installed or until the bracket that attaches the backboard to the gearbox at the center sump interferes with the scrapper. If the scrapper hits the center attachment bracket, the scrapper will need to be cut. **DO NOT CUT THE BACKBOARD ATTACHMENT BRACKET.**
4. Once all the scrappers and all other equipment for the bin is installed, exit the bin and engage the sweep auger and start the unload system. Allow the sweep to make one complete revolution in the bin to make sure there is nothing that will catch on the scrappers.
5. If the scrappers catch on anything stop the unload system and move the obstacle on the floor or, if it can not be moved, adjust the scrapper that was hitting the obstacle until it clears. Back the auger up a couple feet, exit the bin and resume the test.
6. Once the scrappers are adjusted so the auger can make its revolution in the bin freely. Shut the power off and make sure the scrappers are tightened.  
Once the bin has been filled the bin floor and sweep may flex because of the weight of the grain. It may be necessary to adjust the scrappers again.

## INSTALLATION FOR BINS LARGER THAN 39' IN DIAMETER.

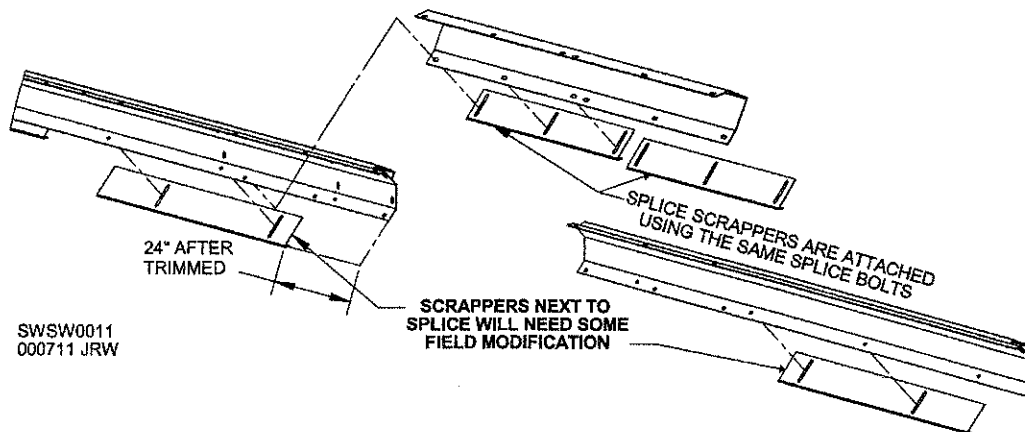

Starting at the splice end of the inside section backboard. Take a scrapper and place it flat against the backside of the backboard with the bent lip towards the floor and away from the auger. Align the scrapper so that the end of the scrapper should be 18" from the splice end of the backboard, the holes in the scrapper should line up with the pre-punched holes in the backboard. The end of this scrapper needs to be shortened so the splice does not interfere with the scrapper. Measure in from the end of the backboard 24", (the amount the splice covers) mark the scrapper and cut it off. This should be approximately 6". The remaining area of the backboard will be covered with the splice which will have it's own scrapper on it.

1. Attach the scrapper to the backboard using the 5/16" x 1" bolts with the head of the bolt on the inside (auger side) of the backboard. Use the flat washer, lock washer and nut on the backside of the scrapper. Adjust the scrapper so they are spaced away from the floor at the desired distance wanted and tighten. **NOTE:** Sitting scrapper to low may limit forward travel of sweep auger and reduce unload capacity.
2. Continue attaching the scrapppers on the backboard until they are all installed or until the bracket that attaches the backboard to the gearbox at the center sump interferes with the scrapper. If the scrapper hits the center attachment bracket, the scrapper will need to be cut. **DO NOT CUT THE BACKBOARD ATTACHMENT BRACKET.**
3. Attach the extension to the inside section of the backboard with the top set of splice holes and remove the bolts holding the splice on the bottom edge of the extension.
4. Take a 24" scrapper and place it flat against the backside of the splice with the bent lip towards the floor and away from the auger. Align the scrapper so that the end of the scrapper is flush with the end of the splice, the holes in the scrapper should line up with the holes in the splice.
5. Attach the scrapper and splice to the backboard using the 3/8" x 3/4" bolts with the head of the bolt on the inside (auger side) of the backboard. Use the lock washer and nut on the backside of the scrapper. Adjust the scrapper so they are spaced away from the floor at the desired distance wanted and tighten
6. Attach the second scrapper to the splice and backboard using the same method as the first.
7. Take a scrapper and place it flat against the backside of the backboard extension with the bent lip towards the floor and away from the auger. Align the scrapper so that the end of the scrapper should be 18" from the splice in the backboard, the holes in the scrapper should line up with the pre-punched holes in the backboard. The end of this scrapper needs to be shortened so the splice does not interfere with the scrapper. Measure in from the splice of the backboard 24", (the amount the splice covers) mark the scrapper and cut it off. This should be approximately 6". The remaining area of the backboard will be covered with the splice which will have it's own scrapper on it.  
**NOTE:** Not all two piece backboards will have 36" scrapppers on the extensions.
8. Continue attaching the scrapppers on the backboard until they are all installed or until the scrapper interferes with the reduction drive wheel. If the scrapper hits the wheel, the scrapper will need to be cut.
9. Once all the scrapppers and all other equipment for the bin is installed, exit the bin and engage the sweep auger and start the unload system. Allow the sweep to make one complete revolution in the bin to make sure there is nothing that will catch on the scrapppers.
10. If the scrapppers catch on anything stop the unload system and move the obstacle on the floor or, if it can not be moved, adjust the scrapper that was hitting the obstacle until it clears. Back the auger up a couple feet, exit the bin and resume the test.
11. Once the scrapppers are adjusted so the auger can make its revolution in the bin freely. Shut the power off and make sure the scrapppers are tightened. Remove the splice on the sweep and mount the drive wheel on the end of the inside section of the auger. Store the extension and splice with scrapppers in a safe location. For operation, attach the extension to the inside split as it is written in the owner's manual for the Sweepway.

**NOTE:** Once the bin has been filled the bin floor and sweep may flex because of the weight of the grain. It may be necessary to adjust the scrapppers again.

# INSTALLATION INSTRUCTIONS FOR SWEEP SCRAPPERS ON CARRY-IN OR OLDER SWEEPWAY

## TYPICAL POWERSWEEP BACKBOARD INSIDE SPLIT OR NON-SPLIT BACKBOARD

SWSW0013  
000711 JRW

SOME HOLES SHOWN MAY NOT BE ON ALL BACKBOARDS

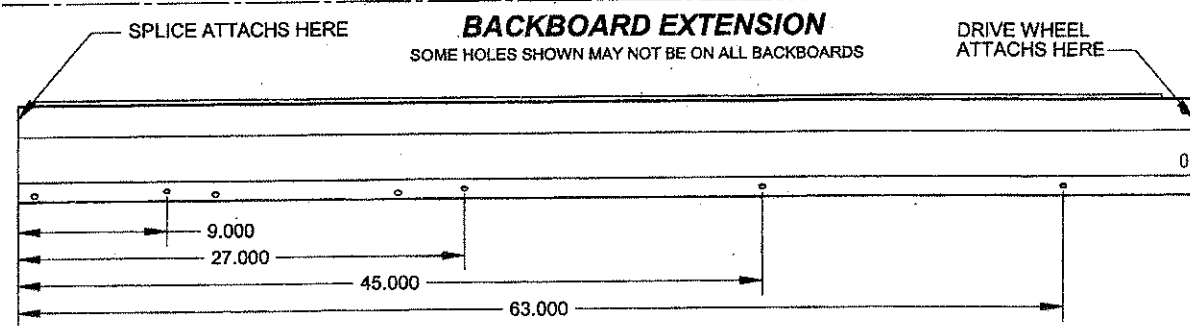
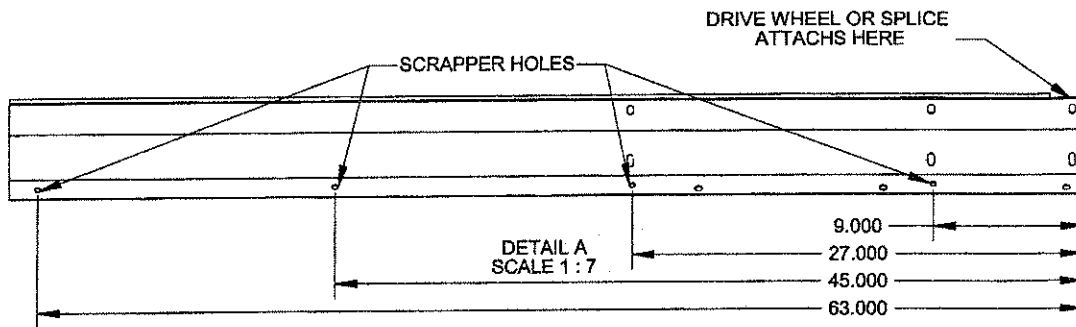

1. Starting at the drive wheel end (or splice end of inside split on a split backboard), measure in 9" from the edge of the backboard toward the center sump and drill a 3/8" hole 1/2" in from the edge on the bottom lip of the backboard.
2. Measure 18" from the center of the new hole towards the center of the bin and drill a 3/8" hole 1/2" in from the edge of the bottom lip of the backboard.
3. Continue step 2 until you reach the end of the backboard.
4. On split backboards, repeat steps 1 – 3 on the extension from the splice end of the extension towards the drive wheel end.

**NOTE:** Not all two piece backboards will need holes drilled for scrappers on the extensions.

5. Follow the instructions for installing the scrappers.



## NOTES

# HORIZONTAL POWERHEAD MOTOR DRIVE & PTO DRIVE

SEE MOTOR AND PULLEY  
LIST AT BACK OF MANUAL

SPSW0016  
940720JB

Figure 11

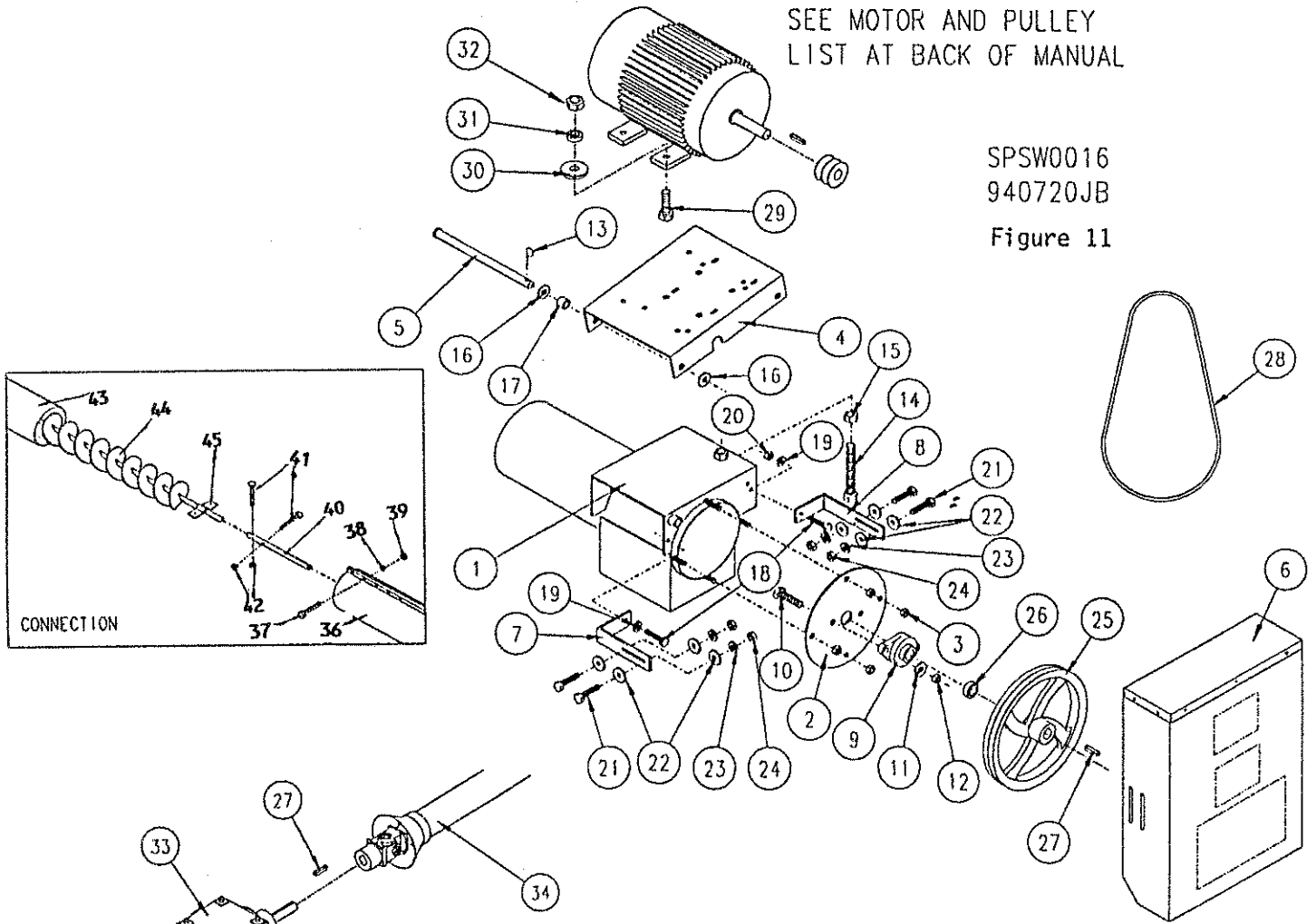
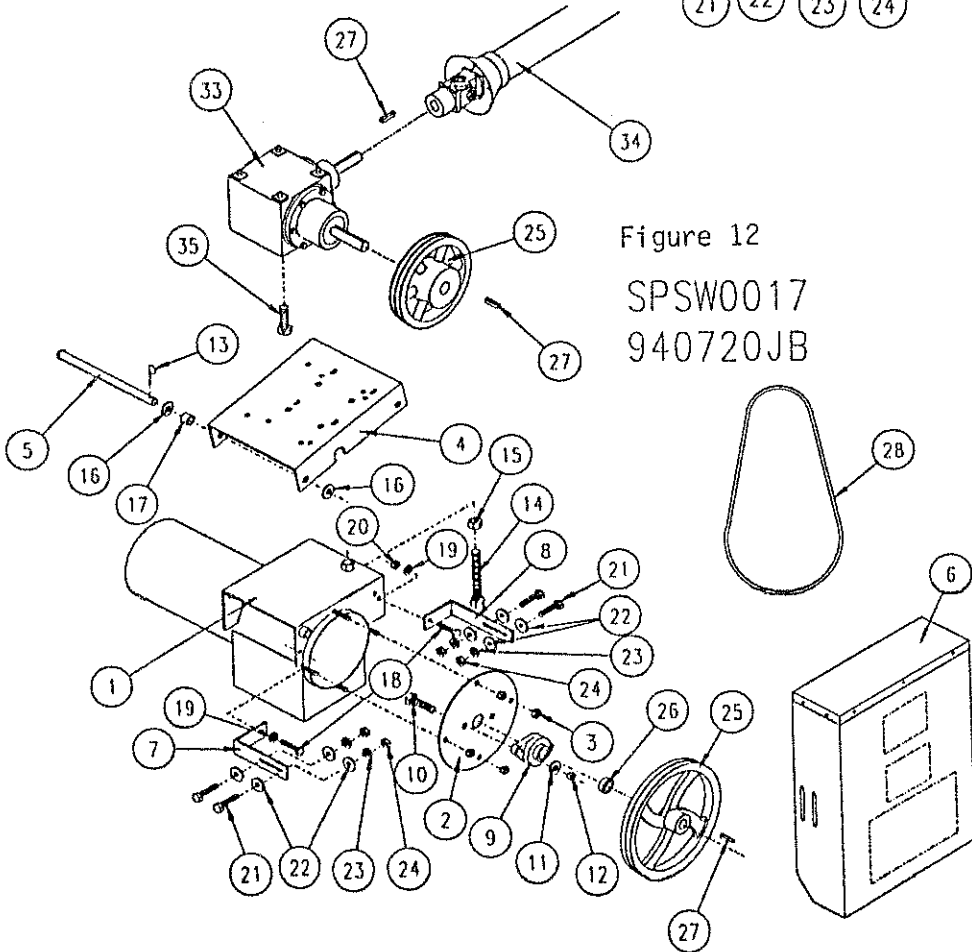

Figure 12

SPSW0017  
940720JB



## HORIZONTAL POWERHEAD MOTOR DRIVE & PTO DRIVE

Ref#	Description	STD	PTO	6" Comp#	8" Comp#	10" Comp#
	Powerhead w/Shield & Bearing	1	1	E5600	E5601	E5602
	HPH w/bearing, Shield, Lrg motor mnt.	1	1	----	E5599	E5611
1	Powerhead Housing Only STD	1	1	E5567	E5568	E5569
2	Bearing Plate 6"	1	1	E5810	----	----
	Bearing Plate 8"	1	1	----	E5811	----
	Bearing Plate 10"	1	1	----	----	E5609
3	Nut, 1/2-13 PLT	4	4	J1030	J1040	J1040
4	Hinged Motor Mount "Small"	1	1	E5746	E5746	E5746
5	Pivot Rod Small	1	1	E5744	E5744	E5744
6	Horz. Motor Shield	1	1	E5748	E5748	E5748
7	Shield Bracket "Left"	1	1	E5750	E5750	E5750
8	Shield Bracket "Right"	1	1	E5752	E5752	E5752
9	Bearing 1" Flange w/ Locking Collar	2	2	J0003	----	----
	Bearing 1-1/4" Flange w/Locking Collar	1	1	----	J0010	J0010
	Bearing Spacer (Not Shown)	1	1	E5791	E5792	E5792
10	Bearing Bolt w/Tab	2	2	E5570	----	----
	Bolt, 1/2-13 x 1-1/2 PLT	2	2	----	J0730	J0730
11	Lockwasher, 7/16 PLT Split	2	2	J1210	----	----
	Lockwasher, 1/2 PLT Split	2	2	----	J1215	J1215
12	Nut, 7/16-14 PLT	2	2	J1035	----	----
	Nut, 1/2-13 PLT	2	2	----	J1040	J1040
13	Hair Pin Clip	1	1	J5412	J5412	J5412
14	Bolt, 3/4-10 x 6" PLT Tap.	1	1	J0824	J0824	J0824
15	Nut, 3/4-10 PLT	1	1	J1051	J1051	J1051
16	Washer 3/4 Flat PLT	2	2	J1130	J1130	J1130
17	Spacer, 3/8" Long	1	1	E5739	E5739	E5739
18	Bolt, 3/8-16 x 1 PLT	2	2	J0606	J0606	J0606
19	Lockwasher, 3/8" PLT Split	2	2	J1205	J1205	J1205
20	Nut, 3/16-16 PLT	1	1	J1020	J1020	J1020
21	Bolt, 5/16-18 x 1 PLT	4	4	J0527	J0527	J0527
22	Flatwasher, 5/16" PLT	8	8	J1111	J1111	J1111
23	Lockwasher, 5/16 PLT Split	4	4	J1200	J1200	J1200
24	Nut, 5/16-18 PLT	4	4	J1002	J1002	J1002
25	Pulley, 12x1" Sngl Groove A-B	1	0	J0375	----	----
	Pulley, 12x1" DBL Groove B	1	0	J0380	----	----
	Pulley, 12x1-1/4" DBL Groove B	1	0	----	J0385	----
	Pulley, 12 x1-1/4" Triple Groove B	1	0	----	J0391	J0391
	Pulley, 12x1-1/4" Sngl Groove A-B	1	0	----	J0388	----
	Pulley, 9 x 1" DBL Groove B	0	2	J0365	J0365	J0365
	Pulley, 9x1-1/4" DBL Groove B	0	1	----	J0366	J0366
26	Locking Collar, 1"	1	1	J0067	----	----
	Locking Collar, 1-1/4"	1	1	----	J0068	J0068
27	Key, 1/4 x 2-1/2"	1	1	E5720	E5720	E5720
28	Belt, BX-48 BX50	1-2	2	J0220	J0220	J0224
	Belt, B52 "3 drive belt"	3	0	----	----	J0227
29	Bolt, 3/8-16 x 1-1/2 PLT	4	0	J0627	J0627	J0627
30	Flatwasher, 3/8 PLT	4	0	J1117	J1117	J1117
31	Lockwasher, 3/8 PLT Split	4	0	J1205	J1205	J1205
32	Nut, 3/8-16 PLT	4	0	J1020	J1020	J1020
33	Gearbox Complete (1 : 1-1/2)	0	1	E5822	E5822	E5822
34	PTO Drive Shaft	0	1	J7205	J7205	J7205
35	Bolt, 7/16-14 x 3/4	0	4	J0690	J0690	J0690
36	Sleeve Connector	1	1	E5423	E5424	E5425
37	Tap Bolt, 3/8-16 x 3 PLT	6	6	J0660	J0660	J0660
38	Lockwasher, 3/8" PLT Split	6	6	J1205	J1205	J1205
39	Nut, 3/8-16 PLT	6	6	J1020	J1020	J1020
40	End Shaft	1	1	E90061	E54151	E54142
41	Bolt, 5/16-18 x 1-3/4 Gr 5	2	4	J0570	----	----
	Bolt, 7/16-14 x 2-1/2" Gr 5	2	4	----	J0720	J0720
42	Locknut, 5/16-18	2	4	J1010	----	----
	Nut, 7/16" - 14	2	4	----	J1035	J1035
43	Unload Tube	1	1	E65---	E65---	E65---
44	Unload Auger	1	1	E64---	E64---	E64---
45	Corn Flipper	1	1	E5416	E54161	E5648
47	Bolt, 5/16-18 x 1-1/4 PLT	8	8	J0550	J0550	J0550
48	Washer, 5/16 PLT Flat	8	8	J1200	J1200	J1200
50	Nut, 5/16-18 PLT	8	8	J1002	J1002	J1002

# BASIC VERTICAL AUGER

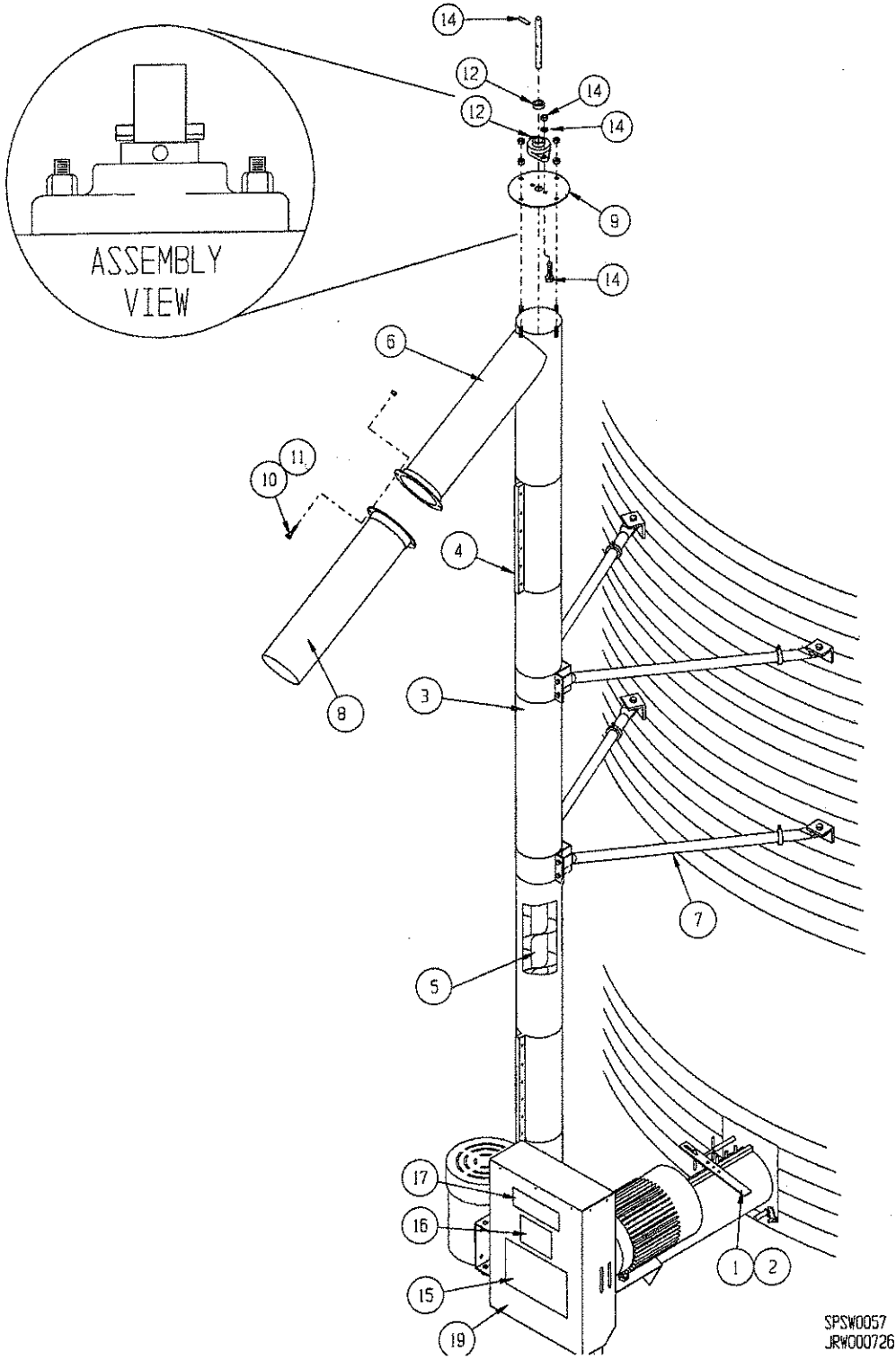

SPSW0057  
JR#000726

Fig. 14

## BASIC VERTICAL AUGER

REF.#	DESCRIPTION	QTY	6"	8"	10"
1	Unload lever arm	1	E5426	E5426	E5426
2	Unloading lever bar	1	E5427	E5427	E5427
3	Auger tube, 12' galvanized	1	E5842	E5843	E57842
4	Connector Sleeve	3	E5423	E5424	E5425
5	16' vertical auger w/flinger & shafts (See next page for fighting & shafts & tubes & flipper)	1	E5846	E5847	E57833
6	Top outlet spout	1	E5812	E5813	E5785
7	30" Support bracket (bipod)	2	E5800	E5801	E5786
8	2-1/2" Truck spout	1	E5814	E5815	E5787
9	Bearing end plate	1	E5810	E5811	E5609
10	Nut, 3/8 - 16 Hex	6-8	J1020	J1020	J1020
11	Bolt, 3/8 - 16 x 1 Gr 5	6-8	J0606	J0606	J0606
12	Flange Bearing, 1" w/lock collar	1	J0003	-----	-----
	Flange Bearing, 1-1/4" w/lock collar	1	-----	J0010	J0010
	Locking collar 1"	1	J0067	-----	-----
	Locking collar 1-1/4"	1	-----	J0068	J0068
13	Bottom shaft, w/keyway	1	E58081	E9751	E58252
14	Rollpin, 5/16" x 1-3/4"	1	J1495	J1495	J1495
	Bolt, 7/16 - 14 x 1-1/2" Gr 5	2	J0710	J0710	J0710
	Lockwasher, 7/16" split	2	J1210	J1210	J1210
	Nut, 7/16-14 hex	2	J1035	J1035	J1035
15	Decal, Never Enter	1	L0301	L0301	L0301
16	Decal, Moving Parts	1	L0284	L0284	L0284
17	Decal, Safe Operation	1	L0281	L0281	L0281
18	Decal, Shield Missing (not shown behind shield)	1	L0271	L0271	L0271
19	Shield, small horizontal	1	E5748	E5748	E5578
20	Shield, Motor Vertical (not shown)	1	E5745	E5745	E5745
21	Top shaft (not shown)	1	E58091	E97711	E58243

## ASSEMBLY INSTRUCTIONS

1. Slide first connector sleeve (4) half way onto unloading tube. Loosely bolt lever bar (2) to connector sleeve (4) with 3/8" x 3" bolts, nuts, and lockwashers. Fig. 14.
2. Remove safety shield (s) (19, 20) from vertical auger boot. Fig. 14
3. Slide boot into sleeve (4) just positioned on unloading tube so that it butts against unload auger. Slide unloading auger shaft through flange bearing of boot while sliding tube together. Boot should be tight against unload tube. Rotate boot to right for assembly of vertical auger on ground. Fig 14.
4. Slide second connector sleeve (4) half way up vertical tube of boot. Loosely bolt in place with 3/8" x 3" bolts, nuts and lockwashers. Fig. 14.
5. Slide 16' vertical fighting (5) (double fighting to be at bottom) through boot so that bottom shaft extends through bearing on bottom of boot. Fig. 14.
6. Slide 12' tube (3) over fighting into second connector sleeve so that tube butts against boot. Tighten connector sleeve. Fig. 14.
7. Attach third connector sleeve (4) to top half of tube (3). Loosely bolt in place. Fig. 14.
8. Slide top spout (6) over fighting while sliding auger shaft (20) through top bearing into connector sleeve (4) so that top spout is against tube. Rotate spout to be desired unloading direction and tighten third connector sleeve (4). Fig. 14.
9. Place locking collar, located (in parts sack) over top shaft (21). Mount pulley on shaft. Drive 5/16" x 1-3/4" rollpin through hole in shaft just above bearing and collar. Check to be sure that rollpin rests against pulley. Lock collar in place on flange bearing and tighten top set screw on locking collar. Fig. 14
10. Mount locking collar shaft protruding from bottom end plate of vertical auger and lock in place on flange bearing. Tighten set screw. Fig. 14.
11. Bolt 2-1/2' truck spout (8) onto top spout (6) using 3/8" x 1-1/2" bolts, nuts and lockwashers. Fig. 14.
12. Using existing bin bolts, attach support brackets (7) to bin wall about 10' up on vertical tube. Fig. 14
13. Using crane, raise vertical auger into position. Provide temporary blocking under boot. Clamp support bracket around vertical auger. Fig. 14.
14. Tighten the bottom, horizontal connector sleeve. Fig. 14
15. Rotate threaded support jack on boot to carry load of vertical auger. Remove temporary blocking under auger. Check to see that tube and auger are aligned. Fig.14
16. Adjust and tighten legs of support brackets. Fig. 14.
17. Slide locking collar over unloading shaft from horizontal auger. Lock in place on flange bearing. Tighten set screw. Fig. 14

## REPLACEMENT VERTICAL FLIGHTING, SHAFTS AND TUBES

VERTICAL FLIGHT NUMBERS INCLUDE FLIPPER AND TOP AND BOTTOM SHAFTS

	6"	8"	10"
Flight for 14' Vertical Auger w/dbl flight 1"	E5806	-----	-----
Flight for 14' Vertical Auger w/dbl flight 1-1/4"	-----	E58071	E5783
Flight for 16' Vertical Auger w/dbl flight 1"	E5846	-----	-----
Flight for 16' Vertical Auger w/dbl flight 1-1/4"	-----	E5847	E57833
Flight for 18' Vertical Auger w/dbl flight 1"	E5848	-----	-----
Flight for 18' Vertical Auger w/dbl flight 1-1/4"	-----	E5849	E57832
Flight for 20' Vertical Auger w/dbl flight 1-1/4"	-----	E58541	E57834
=====			
Vertical Top Shaft 1" x 11-7/8" w/hole	E58091	-----	-----
Vertical Top Shaft 1" x 10" (Prior 1990) w/hole	E5809	E5809	-----
Vertical Top Shaft 1-1/4" x 12-3/8" w/hole	-----	E97711	-----
Vert Top Shaft 1"x1-1/4"x12-3/8" repl w/hole	-----	E9753	-----
Vertical Top Shaft 2" x 15-5/8 w/hole (1998)	-----	-----	E58243
Flipper	E5416	E54161	E5648
=====			
Bottom Shaft 1" x 10-1/8" w/keyway	E58081	-----	-----
Bottom Shaft 1" x 14-1/4" (Prior 1990) w/keyway	E5808	E5808	-----
Bottom Shaft 1-1/4" x 12-1/8" w/keyway	-----	E9751	-----
Bottom Shaft 1" x 1-1/4"x10-1/8" repl w/keyway	-----	E9752	-----
Bottom Shaft 2" x 16-1/8 w/keyway (1998)	-----	-----	E58252
=====			
Tube, Galv. 10' long for 14' Vertical Auger	E5804	E5805	-----
Tube, Galv. 9' long for 14' Vertical Auger	-----	-----	E5784
Tube, Galv. 12' long for 16' Vertical Auger	E5842	E5843	-----
Tube, Galv. 14' long for 18' Vertical Auger	E5844	E5845	-----
Tube, Galv. 16' long for 20' Vertical Auger	F4801	F4915	-----

## TOP DRIVE ASSEMBLY INSTRUCTIONS

1. Slide first connector sleeve half way onto unloading tube. Loosely bolt lever bar to connector sleeve with 3/8"x 3"bolts, nuts, & lockwashers.
2. Remove safety shield(s) from vertical auger boot.
3. Slide boot into sleeve just positioned on unloading tube so that it butts against unload auger. Slide unloading auger shaft through flange bearing of boot while sliding tube together. Boot should be tight against unload tube. Rotate boot to right for assembly of vertical auger on ground.
4. Slide second connector sleeve half way up vertical tube of boot. Loosely bolt in place with 3/8" x 3" bolts nuts & lockwashers.
5. Slide 16' vertical flighting (double flighting to be at bottom) through boot so that bottom shaft extends through bearing on bottom of boot.
6. Slide 12' tube over flighting into second connector sleeve so that tube butts against boot. Tighten connector sleeve.
7. Attach third connector sleeve to top half of tube in same manner as previous connector sleeves. Loosely bolt in place.
8. Slide top spout over flighting while sliding auger shaft through top bearing into connector sleeve so that top spout is against tube. Rotate spout to desired unloading direction and tighten third connector sleeve.
9. Place locking collar (in parts sack) over top shaft. Mount pulley on shaft. Drive 5/16" x 1-3/4" rollpin through hole in shaft just above pulley. Check to be sure that rollpin rest against pulley. Lock collar in place on locking collar.
10. Mount locking collar on shaft protruding from bottom end plate of vertical auger and lock in place on flange bearing. Tighten set screw.
11. Bolt 2-1/2" truck spout onto top spout using 3/8" x 1-1/2" bolts, nuts & lockwashers.
12. Using existing bin bolts, attach support bracket to bin wall about 10' up on vertical tube.
13. Using crane, raise vertical auger into position. Provide temporary blocking under boot. Clamp support bracket around vertical auger.
14. Tighten the bottom, horizontal connector sleeve.
15. Rotate threaded support jack on boot to carry load of vertical auger. Remove temporary blocking under auger. Check to see that tube and auger are aligned.
16. Adjust and tighten legs of support bracket.
17. Slide locking collar over unloading shaft from bearing. Tighten set screw.

# TOP DRIVE ASSEMBLY

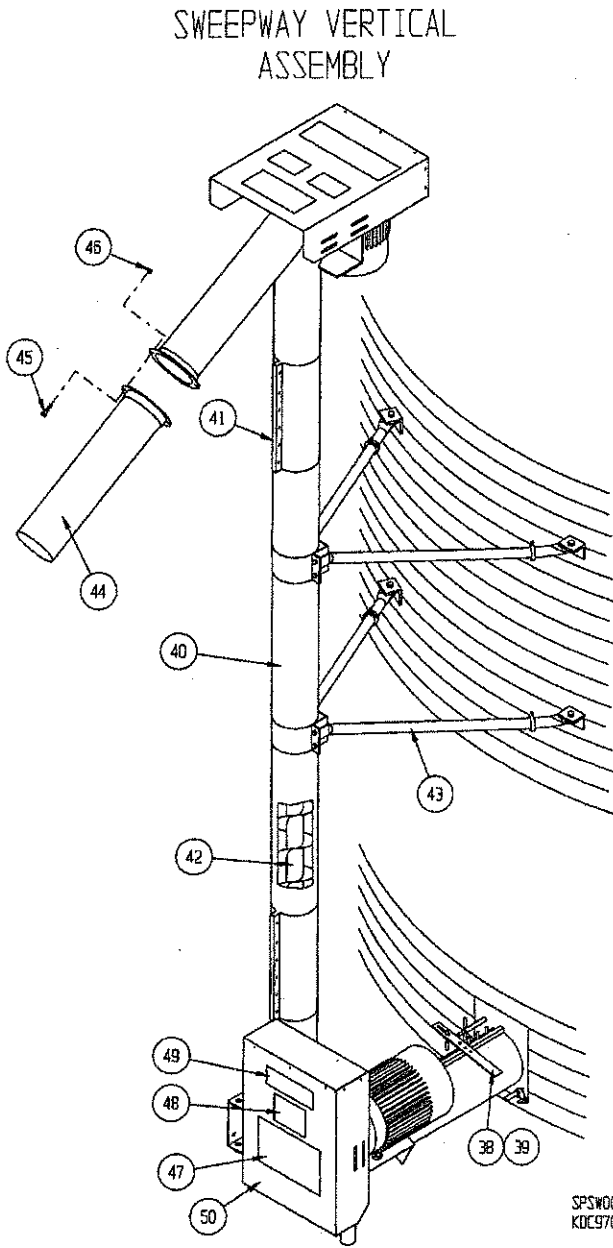
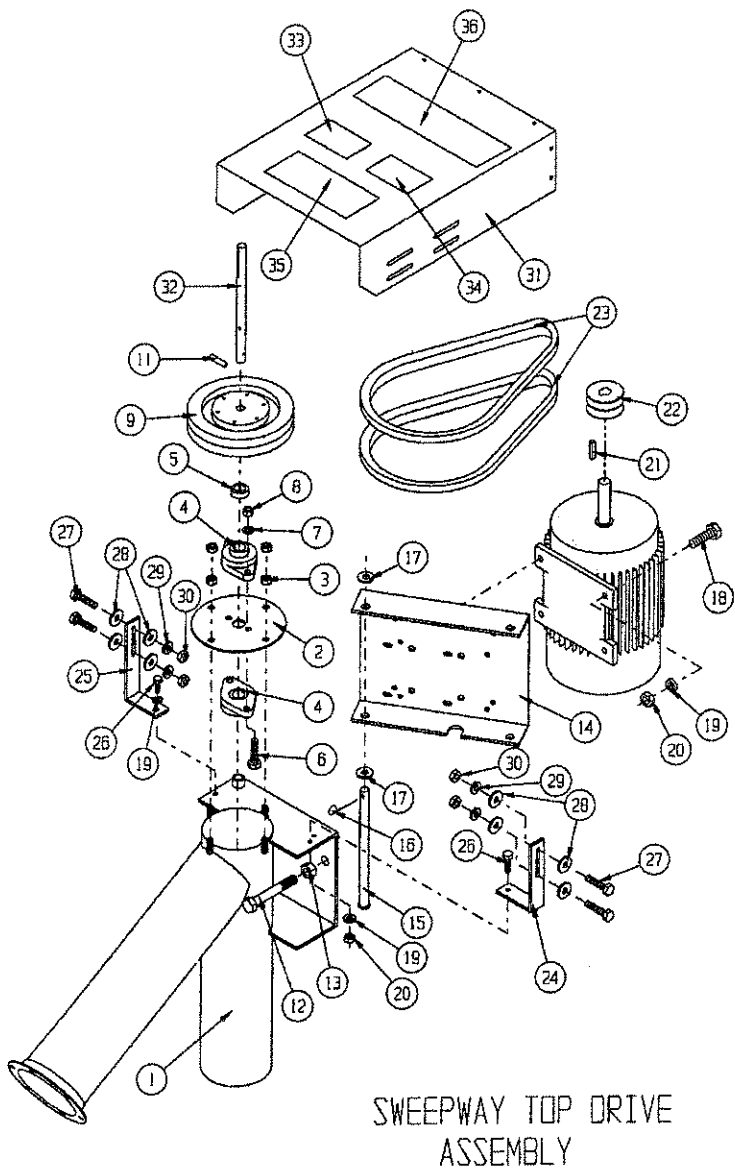



## TOP DRIVE ASSEMBLY

REF#	DESCRIPTION	QTY	6" COMP#	8" COMP#	10" COMP#
1	Power Top Spout Housing Weldment	1	E5929	E5933	E57851
2	Bearing Plate	1	E5810	E5811	E5609
3	Nut, Hex, 1/2-13 PLT	4	J1040	J1040	J1040
4	Flange Bearing	2	J0003	J0010	J0010
5	Locking Collar	1	J0067	J0068	J0069
6	Bolt, 7/16 - 14 x 2 PLT GR 5 HHCS	2	J0718	J0718	J0718
7	Lock Washer, 7/16", PLT Split	2	J1210	J1210	J1210
8	Nut, Hex, 7/16 PLT, Split	2	J1035	J1035	J1035
9	Pulley, 9" OD 2 groove	1	J0365	J0366	J0366
11	Roll Pin, 5/16 x 1-3/4, PLT	1	J1495	J1495	J1495
12	Bolt, 3/4-10x6, PLT GR 5	1	J0824	J0824	J0824
13	Nut, Hex, 3/4-10 PLT	1	J1051	J1051	J1051
14	Hinged Motor Mount, Small	1	E5746	E5746	E5746
15	Pivot Rod, Small	1	E5744	E5744	E5744
16	Hair Pin Clip	1	J5412	J5412	J5412
17	Flat Washer, 3/4 PLT	2	J1130	J1130	J1130
18	Bolt, 3/8-16x 1-1/4 PLT	4	J0616	J0616	J0616
19	Lock Washer, 3/8, PLT, Split	6	J1205	J1205	J1205
20	Nut, Hex, 3/8-16, PLT GR 5	5	J1020	J1020	J1020
21	Key, 1/4" Square x 2-1/2"	1	E5720	E5720	E5721
22	Pulley, 3/2 P.D., 1-1/8 DBL, Cast	1	J0317	J0317	J0317
23	Beit, BX42 (6 & 8") - BX46 (10")	2	J0200	J0200	J0215
24	Shield Bracket, "Left"	1	E5750	E5750	E5750
25	Shield Bracket, "Right"	1	E5752	E5752	E5752
26	Bolt, 3/8-16x1 PLT	2	J0606	J0606	J0606
27	Bolt, 5/16-18x1, PLT GR 5	4	J0527	J0527	J0527
28	Flat Washer, 5/16", PLT	8	J1111	J1111	J1111
29	Lock Washer, 5/16" PLT, split	4	J1200	J1200	J1200
30	Nut, Hex, 5/16-18 PLT	4	J1002	J1002	J1002
31	Shield	1	E5748	E5748	E5748
32	Shaft, power top	1	E58092	E54153	E58244
33	Decal, Danger Replace Missing Shield	1	L0271	L0271	L0271
34	Decal, Caution, safety Instruction	1	L0281	L0281	L0281
35	Decal, Warning Keep Away	2	L0284	L0284	L0284
36	Decal, Danger Never Enter Bin	1	L0301	L0301	L0301
37	Decal, Sukup Logo (Not shown)	1	L0317	L0317	L0317
38	Unload lever arm	1	E5426	E5426	E5426
39	Unloading lever bar	1	E5427	E5427	E5427
40	Auger tube, 12' galvanized - 10" 12' long	1	E5842	E5843	E57842
41	Connector sleeve	3	E5423	E5424	E5425
42	16' Vert. Auger w/flngr & shafts	1	F4750	E58471	E57836
43	Support bracket, 30" (bipod)	1	E5800	E5801	E5786
44	Truck Spout, 2-1/2'	1	E5814	E5815	E5787
45	Bolt, 3/8-16 x 1 Gr5	6-8	J0606	J0606	J0606
46	Nut, 3/8-16 Hex	6-8	J1020	J1020	J1020
47	Decal, Never Enter Bin	1	L0301	L0301	L0301
48	Decal, Moving Parts	1	L0284	L0284	L0284
49	Decal, Safe Operation	1	L0281	L0281	L0281
50	Shield - Small Horiz.	1	E5575	E5575	E5748
51	Decal, Shield Missing	1	L0271	L0271	L0271

# TWO MOTOR DRIVE

SEE MOTOR AND PULLEY LIST IN BACK OF MANUAL

Figure 15

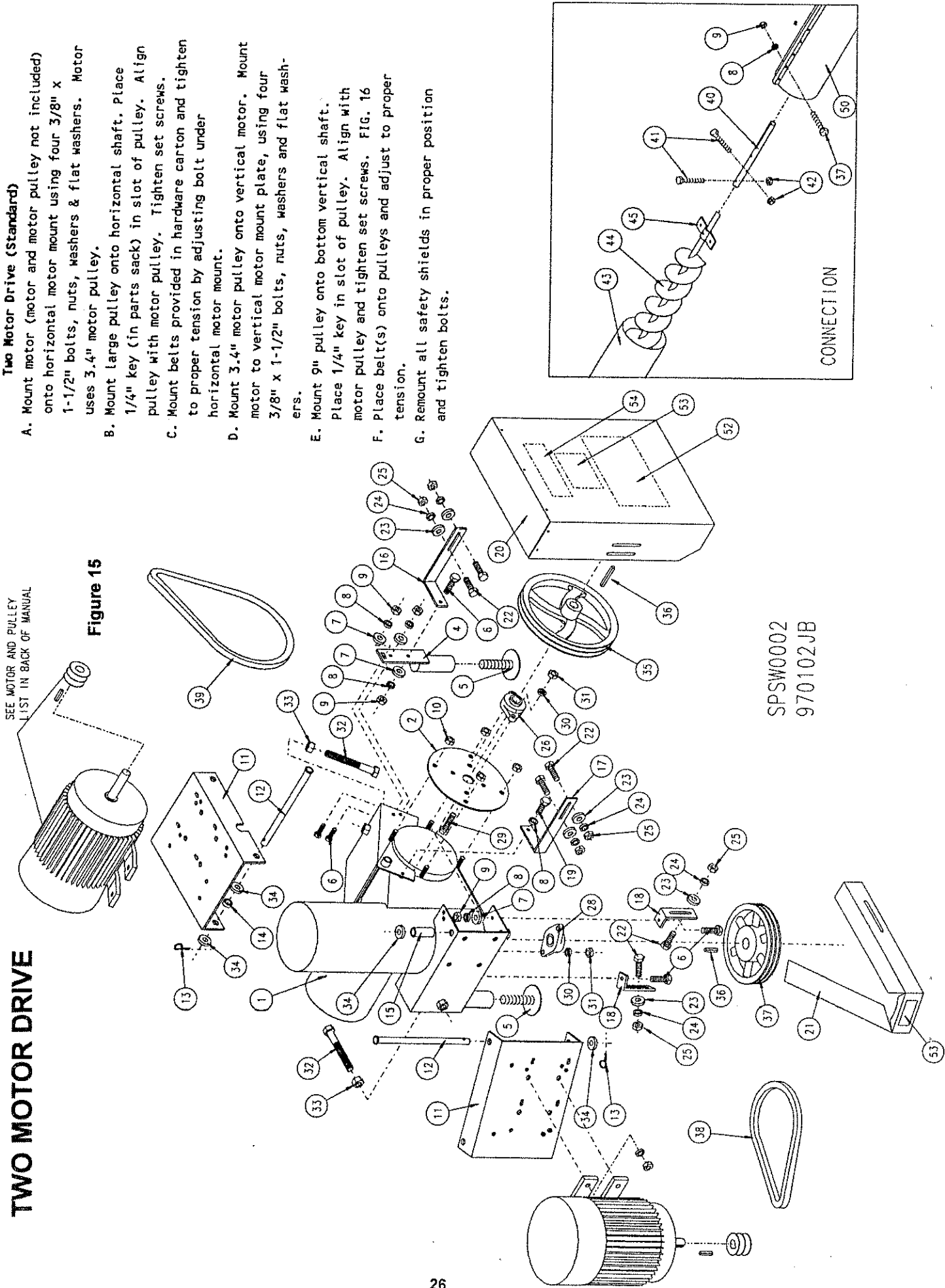

- A. Mount motor (motor and motor pulley not included) onto horizontal motor mount using four 3/8" x 1-1/2" bolts, nuts, washers & flat washers. Motor uses 3.4" motor pulley.
- B. Mount large pulley onto horizontal shaft. Place 1/4" key (in parts sack) in slot of pulley. Align pulley with motor pulley. Tighten set screws.
- C. Mount belts provided in hardware carton and tighten to proper tension by adjusting bolt under horizontal motor mount.
- D. Mount 3.4" motor pulley onto vertical motor. Mount motor to vertical motor mount plate, using four 3/8" x 1-1/2" bolts, nuts, washers and flat washers.
- E. Mount 9" pulley onto bottom vertical shaft. Place 1/4" key in slot of pulley. Align with motor pulley and tighten set screws. FIG. 16
- F. Place belt(s) onto pulleys and adjust to proper tension.
- G. Remount all safety shields in proper position and tighten bolts.

SPSW0002  
970102JB

# ONE MOTOR DRIVE

- One Motor Drive Option**
- A. Follow steps 1-17 in Basic Vertical Installation. Fig. 14.
  - B. Attach large pulley to shaft extending from horizontal unload tube with hub side of pulley out. Place 1/4" key in slot on pulley.
  - C. Mount 50B15 sprocket on shaft protruding from horizontal unload tube with hub side away from pulley.
  - D. Mount 50B15 sprockets on each shaft of gearbox and on bottom shaft of vertical auger. Place 1/4" key in slots of all sprockets and align. Tighten set screws.
  - E. Place short #50 chain and 1/2 connector link on sprocket on bottom of gearbox and sprocket on bottom of vertical auger. Chain can be tightened by adjusting bolts on gearbox mounting plate. Align. FIG. 16.
  - F. Mount motor onto boot plate with 3/8" x 1-1/4" bolts, nuts, washers, and flat washers. Mount 3.4" motor pulley. Align pulleys and tighten set screws. Place belts on pulleys and adjust tension by adjusting under motor mount plate.
  - G. Place long #60 chain and 1/2 connector link on sprocket on side of gearbox and on sprocket on end of horizontal unload tube. Adjust tension by raising or lowering idler sprocket. Align.
  - H. Remount safety shields and tighten bolts.

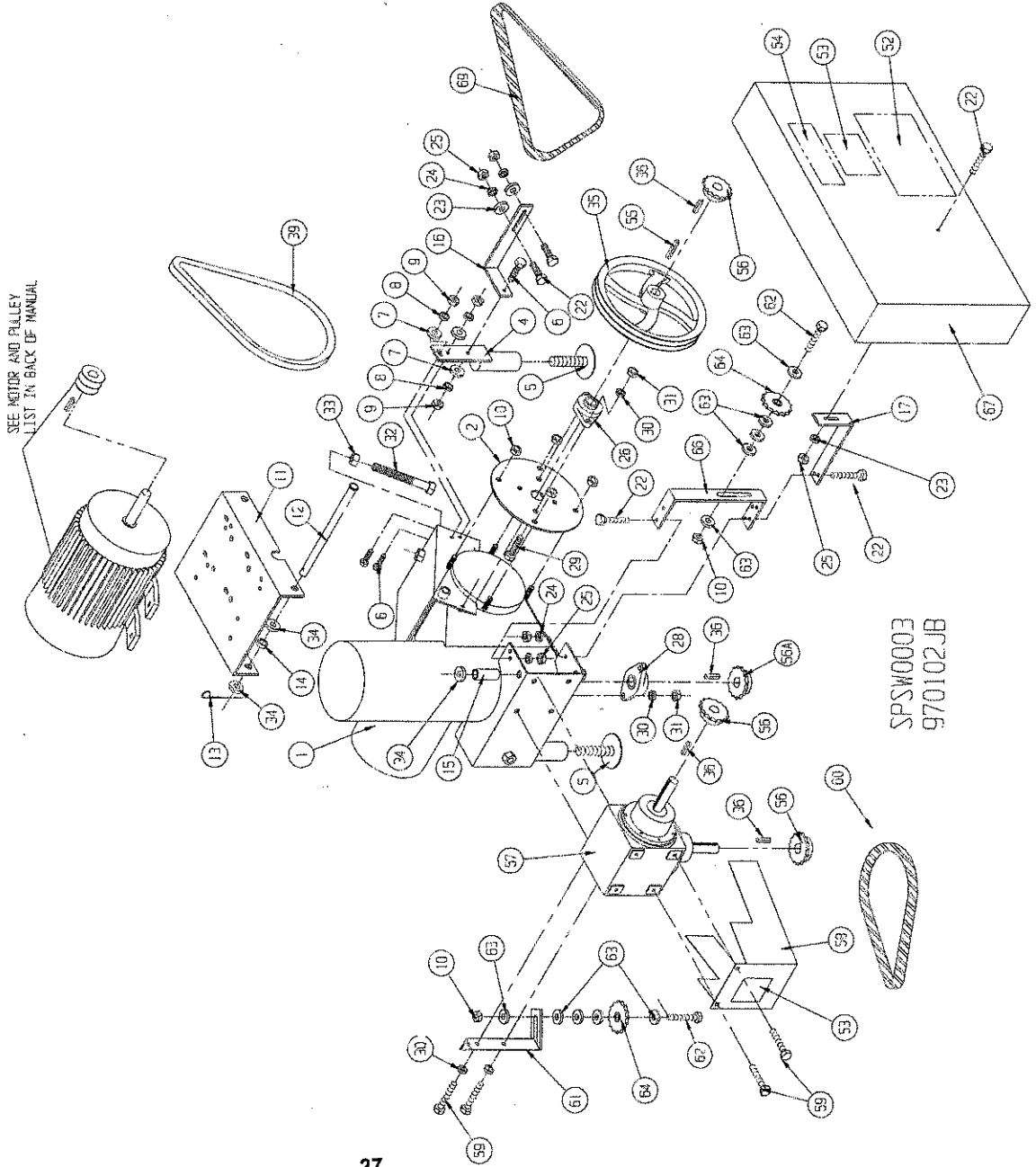

# PTO DRIVE

Figure 17

**- PTO DRIVE OPTION**

- A. Follow steps 1-17 in Basic Vertical Installation, FIG. 14.
- B. Follow steps C & D on Single Motor Drive for mounting sprockets and chain, FIG. 16.
- C. Mount 9" pulley onto shaft of gearbox directly above horizontal unload tube, FIG. 17.
- D. Attach 9" pulley to shaft extending from horizontal unload tube with hub side away from unloading tube. Place 1/4" key in slot on both pulleys. Align pulleys and tighten set screws. Place belts on pulleys and adjust tension by adjusting bolt under motor mount plate.
- E. Follow steps E & G on Single Motor Drive for mounting sprockets and chain, FIG. 16.
- F. Replace safety shields and tighten bolts.

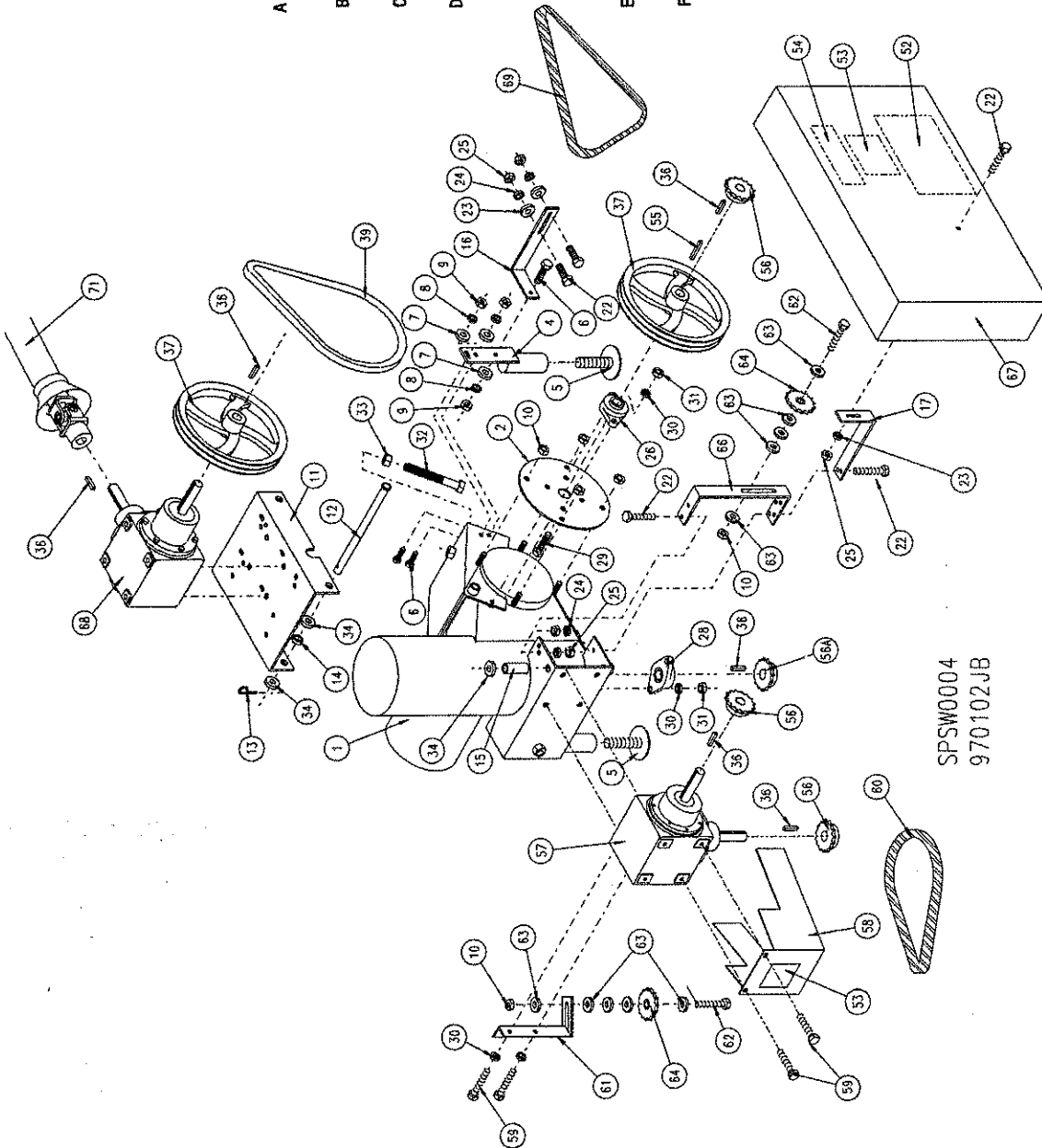

SPSW0004  
970102JB

# VERTICAL BOOT OPTIONS

Ref. #	Description	6"	8"	10"
	Vert. Boot Drive 2 motor	E5816	E5817	E5782
	Vert. Boot Drive 1 motor	E5820	E5821	
	Vert. Boot Drive PTO	E5833	E5834	
1	Vert. Boot Housing	E5767	E5768	E5769
2	Bearing Plate	E5810	E5811	E5609
3	Slide Door "Not Shown"	E5771	E5771	E5771
4	Bolt on Leg Bracket	E5749	E5749	E5749
5	Adjustable Leveling Foot	F4564	F4564	F4564
6	Bolt, 3/8-16 x 1-1/4 PLT Gr5	J0616	J0616	J0616
7	Flat Washer, 3/8 PLT	J1117	J1117	J1117
8	Lock Washer, 3/8 PLT, Split	J1205	J1205	J1205
9	Nut, 3/8-16 PLT	J1020	J1020	J1020
10	Nut, 1/2-13 PLT	J1040	J1040	J1040
11	Motor Mount Hinged Plate "Small"	E5746	E5746	E5746
12	Pivot Rod "Small"	E5744	E5744	E5744
13	Pivot Rod "3 belt drive"			
14	Hair Pin Clip	J5412	J5412	J5412
15	Spacer "Small" 3/8" Long	E5739	E5739	E5739
16	Spacer "Large" 2-5/8" Long	E5740	E5740	E5740
17	Shield Bracket "Right"	E5747	E5747	E5747
18	Shield Bracket "Left"	E5750	E5750	E5750
19	Vertical Shield Bracket	E5571	E5571	E5571
20	Bolt, 3/8-16 x 1" PLT Gr 5	J0606	J0606	J0606
21	Front Motor Shield (Horizontal)	E5748	E5748	E5748
22	Vertical Motor Shield	E5745	E5745	E5745
23	Bolt, 5/16-18 x 1" PLT Gr 5	J0527	J0527	J0527
24	Flat Washer, 5/16, PLT	J1111	J1111	J1111
25	Lockwasher, 5/16, PLT Split	J1200	J1200	J1200
26	Nut, 5/16-18 PLT	J1002	J1002	J1002
	Flange Bearing, 1" W/L.C.	J0003		
	Locking Collar, 1" (not shown)	J0067		
	Flange Bearing, 1-1/4" W/L.C.		J0010	J0010
	Locking Collar, 1-1/4" (not shown)		J0068	J0068
28	Flange Bearing, 1" W/L.C. for 2 bolt	J00031		
29	Flange Bearing, 1-1/4" W/L.C. for 2 bolt	J0710	J0710	J0710
30	Bolt, 7/16-14 x 1-1/2" PLT Gr 5	J1210	J1210	J1210
31	Lockwasher 7/16" PLT Split	J1035	J1035	J1035
32	Nut, 7/16" - 14 PLT	J0824	J0824	J0824
33	Bolt, 3/4-10 x 6" PLT Gr 5	J1051	J1051	J1051
34	Nut, 3/4 - 10 PLT Gr 5	J1130	J1130	J1130
35	Flatwasher, 3/4 PLT	J0375		
	Pulley, 12" OD x 1" B. Single Grv.		J0385	J0385
	Pulley 12" OD x 1-1/4" B. DBL. Grv.		J0391	J0391

Ref.	Description	6"	8"	10"
36	Key, 1/4" x 1-1/4"	G7499	G7499	
	Key, 1/4 x 2-3/4" "3 belt drive"			E5721
37	Pulley, 9" OD x 1" Dbl Grv. (2mtr drive)	J0365		
	Pulley, 9" OD x 1" Dbl Grv. (P.T.O.)	J0365		
38	Pulley, 9" OD x 1-1/4" DBL. Grv.	J0200	J0366	J0366
	Belt, BX 42		J0200	
	Belt, BP 46			J0215
39	Belt, BX 48 - BX50	J0220	J0220	J0224
	Belt, B52, "3 belt drive"			J0227
40	End Shaft	E90061	E54151	E54142
41	Bolt, 5/16-18 x 1-3/4" BLT Gr 5	J0570	J0570	
42	LockNut, 5/16 - 18 PLT	J1010	J1010	
43	Unload Tube	E65	E65	E65
44	Unload Auger	E64	E64	E64
45	Corn Flipper	E5416	E54161	E5648
47	Bolt, 5/16 - 18 x 1-1/4" PLT Gr5	J0550	J0550	
50	Connection Sleeve	E5423	E5424	E5425
51	Tap Bolt, 3/8 - 16 x 3 PLT	J0660	J0660	J0660
52	Decal, Safe Operation	L0281	L0281	L0281
53	Decal, Keep Away From Moving Parts	L0284	L0284	L0284
54	Decal, Never Enter Bin	L0301	L0301	L0301
55	Key, 1-1/4 x 2-3/4 Long	E5721	E5721	
56	Sprocket, 50B15 1" Bore	J1665	J1665	
	Sprocket, 60B15 1" Bore (Sngl&PTO Mtr)	J1694	J1694	
	Sprocket, 60B15 1.25" Br(Sngl&PTO Mtr)	J16941	J16941	
56A	Sprocket, 50B15 1.25" Bore		J1664	
56A	Sprocket, 50B15 1" Bore	J1665		
57	Gear Box	E5822	E5822	
58	Gear Box Shield	E5576	E5576	
59	Bolt, 7/16-14 x 1" PLT	J0695	J0695	
60	Chain #50 43 Links	F4492	F4492	
61	Idler Bracket - (Single Motor & PTO)	E5779	E5779	
62	Bolt, 1/2-13 x 2 PLT Gr 5	J0737	J0737	
63	Flatwasher, 1/2 PLT	J1125	J1125	
64	Sprocket Idler, 50-13	J1685	J1685	
	Sprocket Idler, 60-13 (Single & PTO Mtr)	J1687	J1687	
65	Shield Bracket Long	E9786	E9786	
66	Idler Bracket	E5742	E5742	
67	Large Front Shield, Horizontal	E5826	E5826	
68	Gearbox for Boot PTO	E58221	E58221	
69	Chain, #50 71 Links		E58311	
	Chain, #50 65 Links	E5832		
	Chain, #60 57 Links (Single & PTO Mtr)	E58321		
	Chain, #60 61 Links (Single & PTO Mtr)		E58310	
70	Pulley, 9" DBL. B. Groove w/key	J0365	J0365	
71	PTO Shaft	J7205	J7205	

# 5' INCLINE COMPLETE

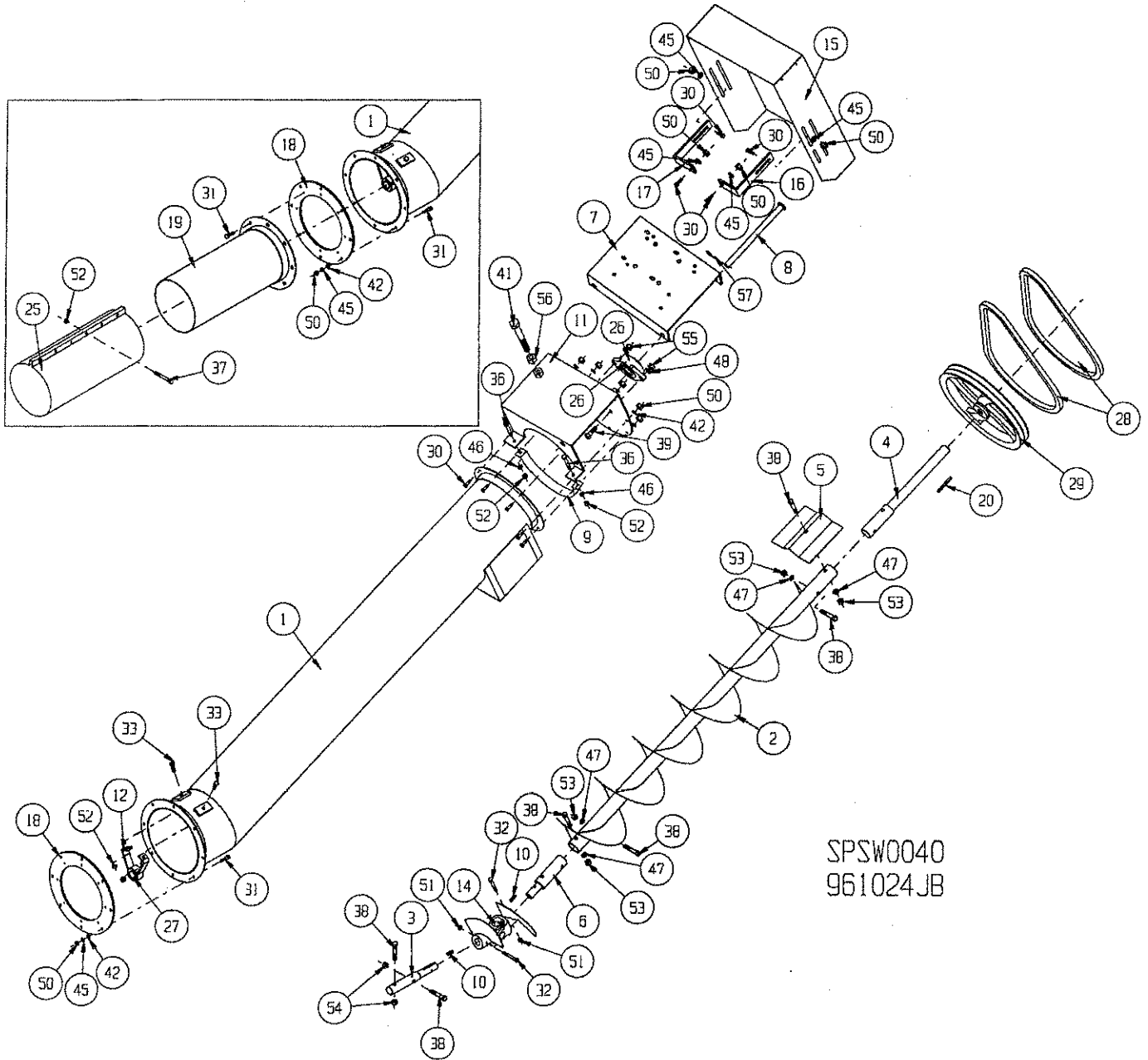

SPSW0040  
961024JB

## 5' INCLINE COMPLETE

REF #	DESCRIPTION	QTY	COMP# 6-8"	COMP# 8-10"
1	Basic Incline, 5'	1	E5950	E5940
2	Flighting & Auger Tube	1	E5622	E5623
3	Shaft, 1-1/4" x 1" x 8-3/4" long w/Keyway	1	E56421	E5624
4	Shaft	1	E54151	E54142
5	Flinger	1	E54161	E5689
6	Shaft, Auger to Knuckle	1	E56411	E56571
7	Hinged Motor Mount	1	E5746	E5746
8	Small Pivot Rod PLT	1	E5744	E5744
9	10" Clamp Band "Narrow"	1	E97161	E5797
10	Keystock, 1/4" x 1" long	2	E5913	E5915
11	Tube Mount	1	E5958	E5948
12	Bushing Support	1	E5956	E5947
14	Knuckle w/Flighting	1	E5970	E5980
15	Motor Shield	1	E5748	E5748
16	Shield Bracket "Left"	1	E5750	E5750
17	Shield Bracket "Right"	1	E5752	E5752
18	Adaptor Plate	1	E5953	E5943
19	Adaptor Sleeve	1	E5954	E5944
20	Key, 1/4" x 2-3/4"	1	E5721	E5721
25	Connector Sleeve	1	E5423	E5424
26	Flange Bearing w/Locking collar 1-1/4"	1	J0010	J0010
27	Bushing, 1" x 1-1/4" x 1-1/4"	1	J00811	J00811
28	Belt, BX 54	2	J0227	J0222
29	Pulley, 14 x 1-1/4", Double "B" Groove	1	J03951	J03951
30	Bolt, 5/16-18 x 1", PLT, Gr. 5	12	J0527	J0527
31	Bolt, 5/16-18 x 1-1/4" PLT, Gr. 5	16	J0550	J0550
32	Bolt, 5/16-18 x 2-1/2, PLT, Gr. 5	2	J0594	J0594
33	Bolt, 3/8-16 x 1" PLT, Gr. 5	2	J0606	J0606
36	Bolt, 3/8-16 x 2-3/4, PLT, Gr. 5	2	J0657	J0657
37	Bolt, 3/8-16 x 3, PLT, Gr. 5	6	J0660	J0660
38	Bolt, 7/16-14 x 2-1/2, PLT, Gr. 5	6	J0720	J0720
39	Bolt, 1/2-13 x 1-1/2, PLT, Gr. 5	2	J0739	J0739
41	Bolt, 3/4 - 10 x 6 PLT, Gr. 5	1	J0824	J0824
42	Flatwasher, 5/16, PLT	16	J1111	J1111
45	Lockwasher, 5/16 PLT, Split	12	J1200	J1200
46	Lockwasher, 3/8, PLT, Split	2	J1205	J1205
47	Lockwasher, 7/16, PLT, Split	4	J1210	J1210
48	Lockwasher, 1/2, PLT, Split	2	J1215	J1215
50	Nut, 5/16-18, PLT	20	J1002	J1002
51	Nut, 5/16-18, PLT, Nylon Lock Nut	2	J1003	J1003
52	Nut, 3/8-16, PLT	10	J1030	J1030
53	Nut, 7/16-14, PLT	4	J1035	J1035
54	Nut, 7/16-14, PLT, Locknut	2	J1034	J1034
55	Nut, 1/2 - 13, PLT	2	J1040	J1040
56	Nut, 3/4 - 10, PLT	1	J1051	J1051
57	Hair Pin Clip	1	J5412	J5412

# INCLINE INSTALLATION INSTRUCTION

1. Remove the motor mount (7) and shield( 15) from the top of the incline.
2. Remove the bolts holding the motor mount base to the incline tube. Connect one end of the support chains to the motor mount with the bolt removed.

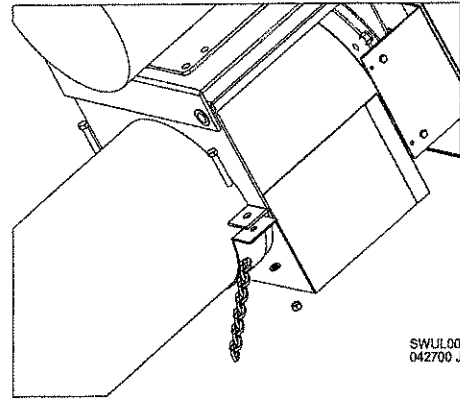

3. Remove two bin bolts spaced equally away from the unload tube ("A" = 80-100") along the seam with the second and third ring of bin sheets ("B" = 60-80")

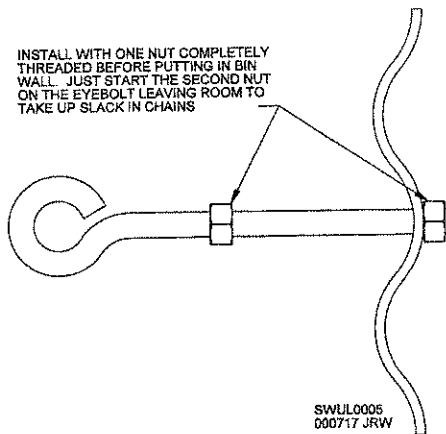
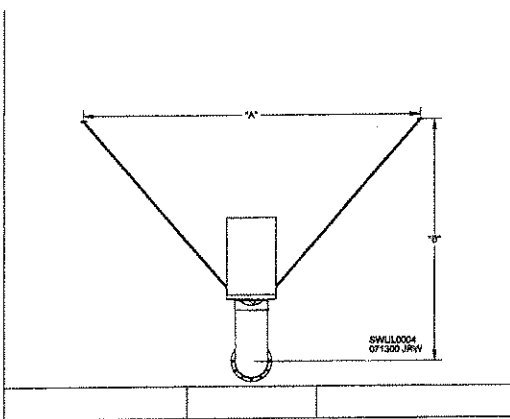

4. For tube and well installations:

- a) Remove the shaft and corn flipper from the end of the unload auger.
  - b) Slide the sleeve connector (25) half way over the end of the unload tube.
  - c) Slide the sleeve adapter (19) into the open end of the sleeve connector.
  - d) Loosely install six 3/8" x 3" bolts (37) and nuts (52) on sleeve connector.
  - e) Rotate the sleeve adapter to match the hole pattern of the angle ring on the incline.
  - f) Tighten all of the bolts on the sleeve connector.
5. Attach the adapter plate (18) to the unload tube angle ring / sleeve adapter using eight 5/16" x 1-1/4" bolts (31), lock washers (45), and flat washers (42).
  6. After sliding the horizontal unload flighting out to attach to incline, temporarily support the incline. Slide the incline shaft (3) into the horizontal flighting and bolt into place using two 7/16" x 2-1/2" bolts (38) and nuts (54).
  7. Bolt the incline to the adapter plate using eight 5/16" x 1-1/4" bolts (31), nuts (50), lock washers (45), and flat washers (42).
  8. Attach chain to the eyebolts and tighten the nuts on the inside of the bin to tighten the chains.
  9. Bolt the motor to the motor mount using four 3/8 x 1-1/2" bolts, flat washers, and lock washers and reattach the motor mount to the incline.
  10. Attach the 14" pulley (29) from the hardware carton to the power shaft (4) extending from the top of the powerhead. Align the pulley with the motor pulley, insert 1/4" key in key slot, and tighten the set screw.
  11. Place belts (28) onto the pulleys and tighten using the motor mount adjustment bolt (41). Belts tension should be as low as possible without allowing the belts to slip.
  12. Replace the safety shield (15). Recheck the belt tension before operation. **NEVER OPERATE UNIT WITHOUT SAFETY SHIELDS SECURELY IN PLACE.** Make sure that all safety decals have been installed and are in good legible condition. See the safety section of this manual for the correct location and descriptions of the safety decals.



# OPERATING INSTRUCTIONS

**Make Sure Sweep Auger is Placed Over Unloading Sumps before Bin is Filled  
(FOR SINGLE PIECE BACKBOARDS)**



**DANGER!**

TO PREVENT SERIOUS INJURY OR DEATH  
DO NOT ENTER BIN DURING  
UNLOADING PROCESS!

TO REMOVE GRAIN:

1. Start vertical and horizontal unload auger. Pull center sump rod (A) to open center sump cover. Unload grain from center until gravity flow stops.
2. After flow stops, re-position lever arm to pull intermediate sump rod (B) allowing additional gravity flow into bottom unloading auger.
3. When grain flow stops, shut off power to sweep. Engage sweep auger by pulling clutch pull rod. **POWER MUST BE SHUT OFF BEFORE ENGAGING SWEEP AUGER TO PREVENT DAMAGE TO CLUTCH ASSEMBLY!**
4. Turn on power. Center sump slide gate must remain open while sweep auger is operating. If a slower flow of grain is desired, (e.g. grinding) a larger pulley should be used on unload auger. Remove remaining grain.
5. Place sweep auger over intermediate sumps and check that stop is retracted before filling bin.

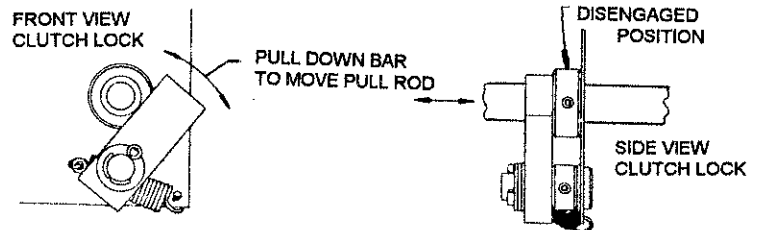
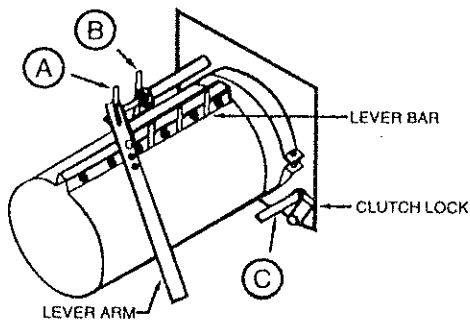

Clutch Lock Assembly

**! DANGER**



**NEVER ENTER BIN**

UNLESS ALL POWER IS LOCKED OUT  
AND ANOTHER PERSON IS PRESENT.

Rotating augers are dangerous!  
Flowing grain may trap and suffocate.

**FAILURE TO HEED THIS WARNING MAY  
CAUSE SERIOUS INJURY OR DEATH.**

LO301-92 SUKUP MANUFACTURING COMPANY SHEFFIELD, IA 50475





**CAUTION:** When the last amount of grain has been removed from the bin, the sweep auger will travel around the bin at an extremely fast rate of speed.

For this reason, we have designed a STOP, which should be installed as Shown on page 9.

This STOP is manually operated by swinging the stop plate out perpendicular to the bin wall. This will put the stop plate into the path of the revolving sweep auger and allow only one revolution of the sweep auger to occur.

Mount the stop near the bin door so that it can be positioned without entering the bin. Make sure to swing the stop back it can be positioned without entering the bin. Make sure to swing the stop back against the wall after loading is completed, before re-filling the bin with grain.

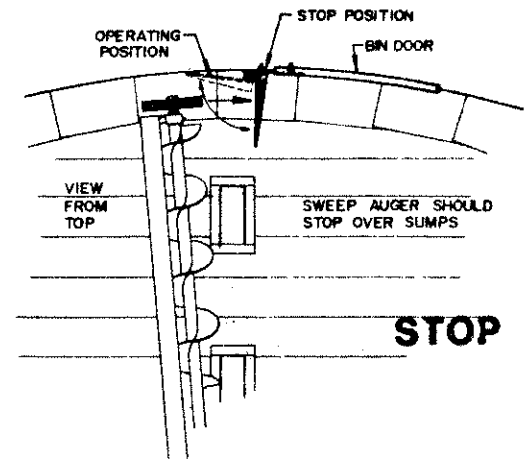

## LUBRICATION

In gearboxes, use # 140 transmission grease. Gearboxes should be checked every time bin is empty. Check plugs are on back or top of, gearboxes. Gearbox should be about half full. Add grease through grease zerks on top of gearboxes for the two sump gearboxes. On single motor vertical drive, add grease through fill plug. Grease roller chains in sump every time bin is empty.

## FOR SPLIT BACKBOARDS - 42' & OVER

**NOTE:** Sweep augers 42' and larger are built in two or more sections:

a. Sukup recommends that only the inside sweep section be installed and operated for the first revolution around the bin, than the outside sweep be installed to complete unloading.

b. The bin should be swept in stages, beginning with the inside section, (it is recommended that the inner section be used first) than the outer section be added and remainder of bin be swept.



**Never enter bin while equipment is operating. Shut off complete system before adding outer section.**

1. Start vertical and horizontal unload auger. Pull center sump rod to open center sump cover. Unload grain from center until gravity flow stops.
2. After flow stops, re-position lever arm to pull intermediate pull rod allowing additional gravity flow into bottom unloading auger.
3. When grain flow stops, shut off power to equipment. Engage sweep auger by pulling clutch pull rod. **POWER MUST BE SHUT OFF BEFORE ENGAGING SWEEP AUGER TO PREVENT DAMAGE TO CLUTCH ASSEMBLY!!**
4. Turn power on. Sweep auger will not be used. On first pass of auger around bin, only the inside section of sweep will be used. Remove remaining grain. Center sump slide gate must remain open while sweep auger is operating. If a slower flow of grain is desired, (e.g. grinding), a larger pulley should be used on unload auger.
5. When last of grain has been removed by inside section, shut off power and LOCK OFF so no one will accidentally turn on power while someone is in the bin. Connect the two sections of sweep as described on page 8.
6. Unload the remainder of the grain, using both sections.
7. Before filling bin again, remove the channel iron spacer and 6" auger splice and bolt sweep wheel back onto inside section. Outside section can be left in bin. Make sure sweep is over intermediate sumps when taking apart and before filling Make sure stop is retracted before filling.

# SPLICE - SPLIT BACKBOARD

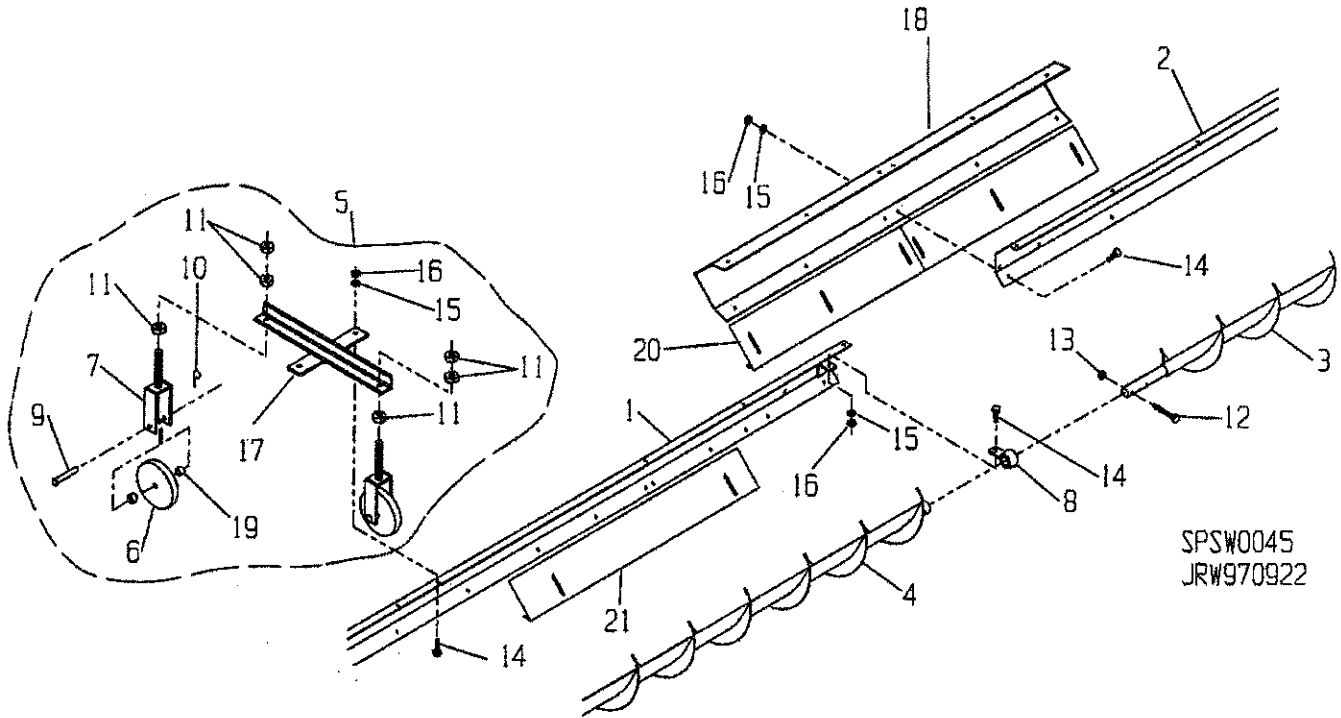

SPSW0045  
JRW970922

REF #	DESCRIPTION	QTY	8"	10"
1	Inside auger & backboard ass'y	1	E7041	E7042
2	Outside " " " " 42'	1	E7051	E7056
	" " " " " 48'	1	E7052	E7052
	" " " " " 60'	1	E7053	E7058
3	Outside auger only*	1	E67---	E68---
4	Inside auger only*	1	E67---	E68---
5	Support wheel assembly	1	E70191	E70191
6	Wheel 5"	2	E7009	E7009
7	Wheel Yoke	2	E7008	E7008
8	Sweep auger bushing	1	E6065	E6065
9	Picker Pin, 1/2" x 3"	2	J1560	J1560
10	Hair pin, 3/32" x 2"	2	J5410	J5410
11	Nut, 1/2 - 13 Hex	6	J1040	J1040
12	Bolt, 5/16 - 18 x 1-1/2 Gr 5	2	J0565	J0565
13	Locknut, 5/16-18	2	J1010	J1010
14	Bolt, 3/8 - 16 x 1 Gr 5	15	J0606	J0606
15	Nut, 3/8 - 16 Pltd Hex	15	J1020	J1020
16	Lockwasher, 3/8" split	15	J1205	J1205
17	Support wheel bracket	1	E7020	E7021
18	Splice Stiffener	1	E7011	E7012
19	Spacer	4	E9294	E9294
20	Scraper, Sweep, Splice 24"	0 or 2	E8425	E8425
21	Scraper, Sweep, 36" Qty depends on length of backboard	3-7	E8420	E8420

\*Specify bin size.

# REDUCTION DRIVE

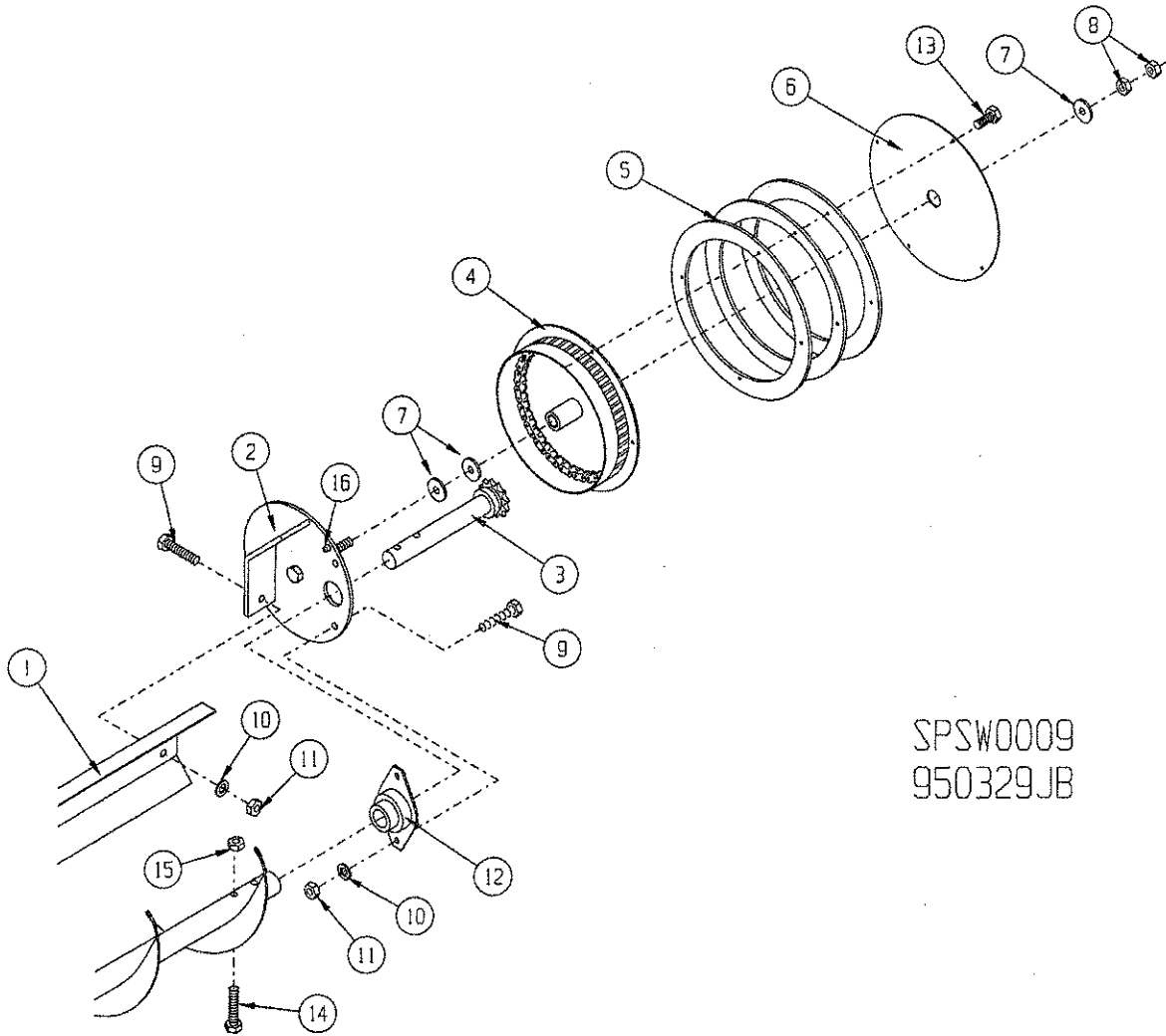

SPSW0009  
950329JB

REF#	DESCRIPTION	QTY	6" COMP#	8" COMP#	10" COMP#
1	Reduction Wheel Complete	1	E6041	E6042	E6043
	Outside Auger & Backbd. Ass'y 42	1	E7046	E7051	E7056
	" " " " " 48	1	E7047	E7052	E7057
	" " " " " 60	1	E7048	E7053	E7058
2	Front Plate Mount	1	E6050	E6051	E6052
3	Drive Shaft w/8tooth Sprocket	1	E6049	E6049	E6049
4	Back Plate w/Roller Chain	1	E6048	E6048	E6048
5	Rubber & Belt Ring Set Of 2 or 3 depending on thickness	1	E6012	E6012	E6012
6	Back Plate	1	E60451	E60451	E60451
7	FlatWasher, 1/2" Plt	3	J1125	J1125	J1125
8	Nut, 1/2-13 Plt	2	J1040	J1040	J1040
9	Bolt, 3/8-16 x 1" Plt Gr5	4	J0606	J0606	J0606
10	LockWasher, 3/8 Plt, Split	4	J1205	J1205	J1205
11	Nut, 3/8-16 Plt	4	J1205	J1205	J1205
12	Flange Bearing, 1" FHFT20516 W/LC	1	J0003	J0003	J0003
13	Tek Screw, #10-16 x 2"	4	J0503	J0503	J0503
14	Bolt, 5/16 - 18 x 1-1/2" Gr 5	1	J0565	J0565	J0565
15	Locknut, 5/16 - 18	1	J1010	J1010	J1010
16	Zerk, 1/4" Drive in Grease	1	J3605	J3605	J3605

# MOTORS

## OPTIONAL - FARM-DUTY MOTORS (1750)

HP	PH	FRAME	SHAFT	LBS.	COMP. #
2	1	E182T	1-1/8"	67	H2175
2	3	F145T	7/8"	50	H2475
3	1	J184T	1-1/8"	113	H2845
3	3	E182T	1-1/8"	60	H3345
5	1	L184T	1-1/8"	122	H3675
5	3	F184T	1-1/8"	72	H4190
7.5	1	K215T	1-3/8"	130	H4900
7.5	3	213T	1-3/8"	84	H4910
10	1	215T	1-3/8"	143	H5300
10	3	215T	1-3/8"	94	H5310
15	3	254T	1-5/8"	141	H6110
20	3	256T	1-5/8"	188	H6610

## MOTOR PULLEYS

Description	Comp#
3.5" OD sgl gr mtr pulley, 7/8" bore (optl)	J0310
" " " " " " 1-1/8" " "	J0312
" " " " " " 1-3/8" "	J0313
3.5" OD dbl gr mtr pulley 7/8" bore cast (optl)	J0315
" " " " " " 1-1/8" " " "	J0317
" " " " " " 1-3/8" " " "	J0318
3.2" OD triple gr mtr pulley 1-3/8" " " "	J0331

# CENTER SUMP 6" & 8"

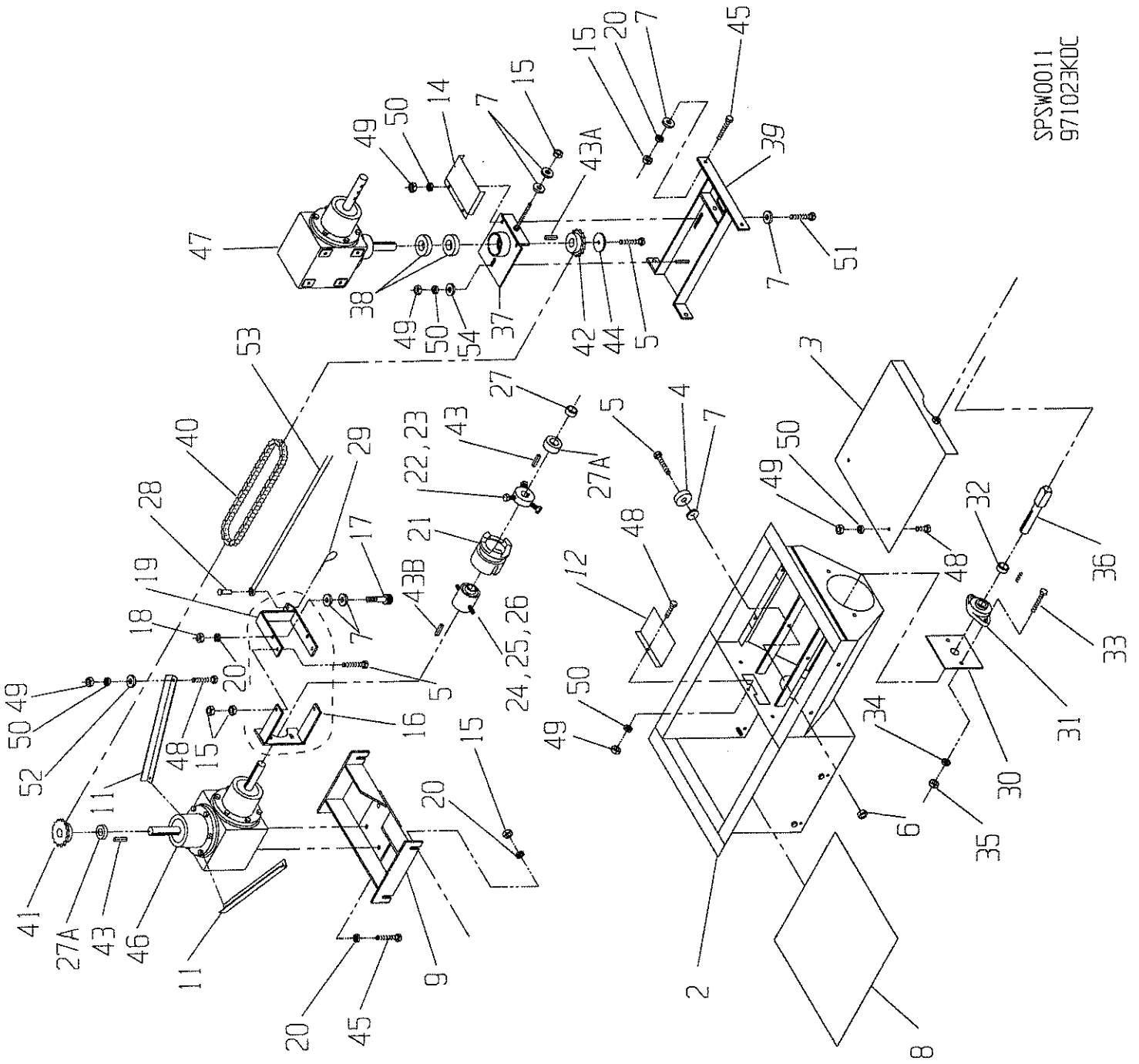

SPSW0011  
971023KDC

## Center Sump 6" & 8"

Ref#	Description	Qty	6"Comp#	8"Comp#
1	Sweep sump & grbxs, cml	1	E5331	E5332
2	Center sump shell	1	E5300	E5301
3	Center slide gate	1	E5303	E5304
4	1-1/2" Roller brg 6203RS6C3	6	J0045	J0045
5	Bolt,3/8-16 x 1-1/4" GR5	8	J0616	J0616
6	Locknut, 3/8-16	6	J1025	J1025
7	Washer, 3/8" pltd flat	19	J1117	J1117
8	Center sump cover	1	E5306	E5306
9	Rear gearbox support bkt	1	E5307	E5307
11	Center sump brace	2	E5308	E5308
12	Chain cover	1	E5309	E5309
13	Tek screw,#10-16 x 1-1/2	58-114	J0502	J0502
14	Cover, Gearbox Support	1	E5312	E5312
15	Nut, 3/8-16 pltd hex	20	J1020	J1020
	Clutch Shifter Arm Complete Ass'y	1	E5313	E5313
16	Clutch shifter arm supprt brkt	1	E5311	E5311
17	.75 Bearing(cam follower)	2	J0035	J0035
18	Nut, 3/8-24 hex	2	J1030	J1030
19	Clutch shifter arm weld.	1	E53131	E53131
20	Lockwasher, 3/8" split	19	J1205	J1205
21	Engaging clutch, three tooth	1	E60011	E60011
22	3 Dog clutch disc	1	E6002	E6002
23	Bolts, 1-1/2 x 1/2"	3	J0730	J0730
24	Clutch base w/set screws	1	E6003	E6003
	Snap Ring (Not Shown) 2.047"	1	J3597	J3597
25	Set Screw, 1/2-13 x 1-1/4"	2	J1390	J1390
26	1" Ctr pbk brg FHSR205-16-W/SS	1	J0030	J0030
27	Spacer 3/4"long for 6" & 8"	1	E6004	E6004
27A	Spacer 5/8" long	2	E60041	E60041
28	Picker pin, 1/2 x 1-1/2"	2	J1550	J1550
29	Hairpin clip, 3/32 x 2"	1	J5410	J5410
30	Mounting plate	1	E6005	E6005
31	Flange bearing, 1"	1	J0003	J0003
32	Locking collar, 1"	1	J0067	J0067
33	Bolt, 7/16-14 x 1-1/2" GR5	2	J0710	J0710
34	Lockwasher, 7/16" split	6	J1210	J1210
35	Nut, 7/16-14 hex	2	J1035	J1035
36	Square end auger shaft	1	E6006	E6006
37	Top grbx brg support slide plate	1	E5317	E5317
38	Sealed brg, 1-1/4" 1654-2RS	2	J0060	J0060
39	Top gearbox support brkt	1	E5318	E5318
40	#50 Chain(73 links & 1 connector)	1	E5319	E5319
41	#50B15 sprocket 1" bore	1	J1665	J1665
42	#50A18 sprocket 1" bore	1	E5837	E5837
43	Key, 1/4" sq x 1"	2	E5915	E5915
43A	Key, 1/4" x 3/4"	1	G7508	G7508
43B	Key, 1/4" x 1-1/2"	1	E9007	E9007
44	Spacer washer, 3/8"	1	E5324	E5324
45	Bolt, 3/8-16 x 1 GR5	10	J0606	J0606
46	Rear gearbox complt(See Grbx Sec)	1	E5320	E5320
47	Top gearbox complt (See Grbx Sec)	1	E5325	E5325
48	Bolt, 5/16-18 x 3/4" Gr5	8-12	J0520	J0520
49	Nut, 5/16-18 pltd hex	10-14	J1002	J1002
50	Lockwasher, 5/16" split	9	J1200	J1200
51	Bolt,5/16-18x2-1/4"Carriage,Tap	2	J0588	J0588
52	Washer, 5/16 flat pltd	4	J1111	J1111
53	Clutch pull rod(specify bin sz)	1	E61--	E61--
54	Washer, 2-1/2"OD x 3/8"ID	1	J1140	J1140

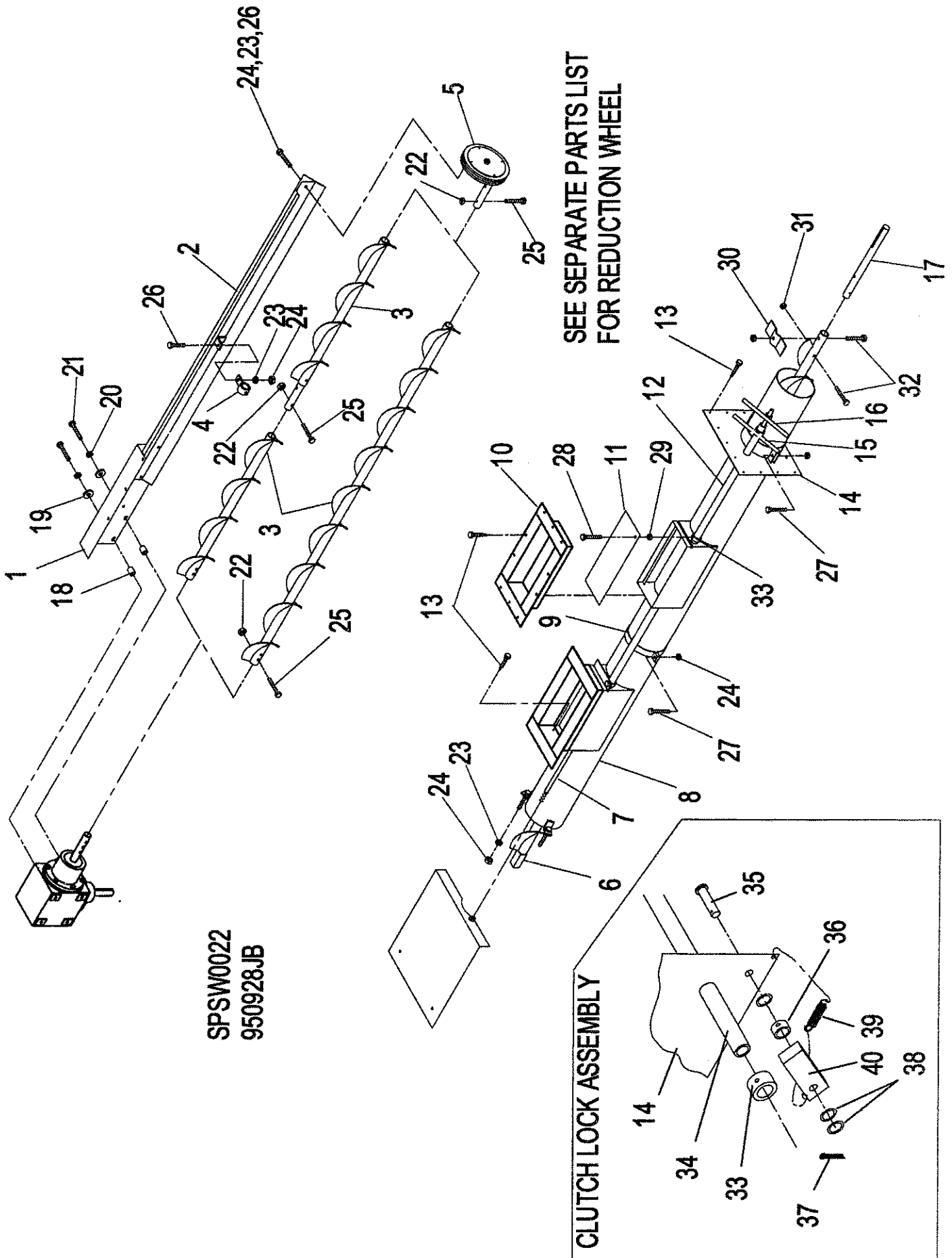

SPSW0022  
950928JB

SEE SEPARATE PARTS LIST  
FOR REDUCTION WHEEL

CLUTCH LOCK ASSEMBLY



## TUBE, AUGERS, & SWEEP 6", 8", & 10"

REF #	DESCRIPTION	QTY	6" COMP #	8" COMP #	10" COMP #
1	Extension Bracket	1	E6949	E6949	E6974
2	Decal, Never Enter Bin	1	L0301	L0301	L0301
3	Auger & Coupling Only *	1	E67--	E67--	E68--
4	Support Bushing	0-1	E6065	E6065	E6065
5	Reduction Wheel	1	E6041	E6042	E6043
	Reduction Wheel (galvanized carry in)	1	E9890	E9890	-----
6	Unload auger w/Sq coupler, corn flipper and power shaft	2	E64--	E64--	E64--
7	Center Sump Gate Pull Rod *	1	E61--	E61--	E61--
8	Unload Tube *	1	E65--	E65--	E66--
9	Clutch Rod Support Clamp	1	E5314	E5315	E53162
10	Top Half Intermediate Sump	1-5	E5410	E5410	E5411
11	Intermediate Slide Gate	1-5	E5409	E5409	E5409
12	Intermediate Sump Gate Pull Rod *	1	E62--	E62--	E62--
13	Tek Screw, #10 - 16 x 1-1/2"	58-114	J0502	J0502	J0502
14	Bin Collar w/Clutch Lock Assy	1	E5405	E5406	E5362
15	Handle, Intermediate Sump Rod 7/8"	1	E5404	E5404	E5404
16	Handle, Center Gate 1/2"	1	E5403	E5403	E5403
17	Auger Shaft 1998	1	E90061	E54151	E54142
18	Spacer, 6 & 8", 1/2IDx1", 10" 1/2IDx1-3/8"	4	E6014	E6014	E6013
19	Washer, Flat, 7/16"	4	J1120	J1120	J1120
20	Lockwasher, Split, 7/16"	6	J1210	J1210	J1210
21	Bolt, 7/16 - 14 x 1-3/4" GR 5, 6" & 8"	4	J0713	J0713	-----
	Bolt, 7/16 - 14 x 2" GR5, 10"	4	-----	-----	J0718
22	Locknut, 5/16 - 18	6	J1010	J1010	J1010
23	Lockwasher, Split, 3/8"	19	J1205	J1205	J1205
24	Nut, Hex, 3/8 - 16, PLTD	20	J1020	J1020	J1020
25*	Bolt, 5/16-18 x 1-1/2" GR5	6	J0565	J0565	J0565
26	Bolt, 3/8 - 16 x 1" GR 5	10	J0606	J0606	J0606
27	Bolt, Threaded, 3/8-16x 1-3/4" GR 5 FL	2	J0640	J0640	J0640
28	Bolt, 5/16-18 x 3/4" GR 5	8-12	J0520	J0520	J0520
29	Nut, Hex, 5/16 - 18 PLTD	10-14	J1002	J1002	J1002
30	Corn Flipper Only	1	E5416	E54161	E5648
31	Locknut, 5/16-18	2	J1010	-----	-----
	Locknut, 7/16-14	2	-----	J1034	J1034
32	Bolt, 5/16-18 x 2" GR 5	2	J0585	-----	-----
	Bolt, 7/16-14 x 2-1/2"	2	-----	J0720	-----
	Bolt, 7/16-14 x 3"	2	-----	-----	J0722
33	Shaft Collar, 7/8"	1-6	J1330	J1330	J1330
34	Clutch Pull rod *	1	E61---	E61---	E61---
35	Picker Pin, 1/2 x 1-1/2"	2	J1550	J1550	J1550
36	Shaft Collar, 1/2"	1	J1320	J1320	J1320
37	Cotter, 1/8 x 1"	1	J1420	J1420	J1420
38	Bushing, Machine, 1/2" x 18 ga.	3	J1250	J1250	J1250
39	Pawl Spring	1	J2360	J2360	J2360
40	Clutch Latch	1	E5408	E5408	E5408

\* Specify Bin Size

# 10" CENTER SWEEPWAY SUMP

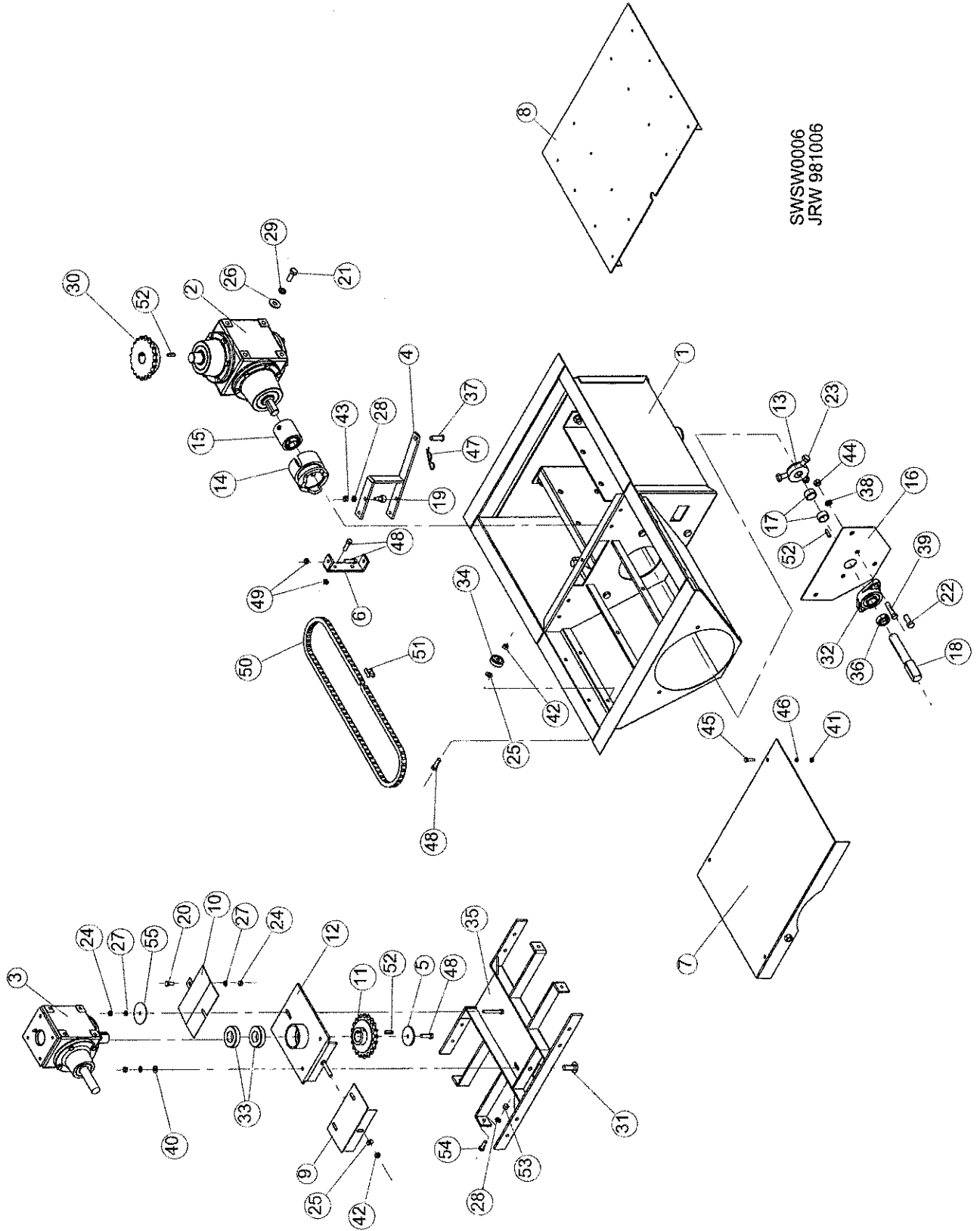

SWSW0006  
JRW 981006

## 10" SWEEPWAY CENTER SUMP

REF #	DESCRIPTION	QTY	COMP #
1	10" Sweepway Sump	1	E5350
2	Gearbox, Lower, Complete 10", 1998	1	E5360
3	Gearbox, Top, Complete 10", 1998	1	E5370
4	Clutch Arm, 10"	1	E5351
5	Washer, Spacer, 3/8" ID 2.25 OD	1	E5324
6	Clutch Bracket 10"	1	E5352
7	Slide Gate Weldment	1	E5353
8	Sump Cover	1	E5354
9	Gearbox Support Cover	1	E5357
10	Chain Cover	1	E5358
11	Sprocket, Machined, 60B20, W 1.25 Bore	1	E5368
12	Bearing Support Plate	1	E5355
13	Base, Clutch, 3 bolt, 2.5 x 1-7/8	1	E6002-01
14	Clutch, Engaging, 3 teeth	1	E60011
15	Clutch, BS & Pilot bearing, 2 bolt	1	E60031
	Snap Ring, 2.047	1	J3597
	Bearing, 1", Cnt, F/PB, W/SS, FHRS205 -16	1	J0030
	Setscrew, 1/2 x 1-1/4 Allen Head	2	J1390
16	Mounting Plate	1	E60051
17	Clutch Spacer	2	E60041
18	Square Shaft	1	E6006
19	Bearing, .75, Cam Follower, CF	2	J0035
20	Screw, 5/16 - 18, 3/4" PLT	1	J0520
21	Screw, 1/2- 20, 1.25", PLT	8	J0724
22	Screw, 1/2 - 13, 1.25, PLT	1	J0728
23	Screw, 1/2 - 13, 1.5, GR 5 HHCS	3	J0730
24	Nut, Hex, 5/16 - 18 PLT	4	J1002
25	Washer, Flat, 3/8, PLT	7	J1117
26	Washer, Flat, 1/2"	8	J1125
27	Washer, Lock, 5/16, PLT, Split	4	J1200
28	Washer, Lock, 3/8, PLT	2	J1205
29	Washer, Lock, 1/2, PLT	8	J1215
30	Sprocket, 60B20, 1-1/4" Bore	1	J1695
31	Bolt, Carriage, 5/16 - 18, 2.5	2	J0589
32	Bearing, Flange, 1", with collar	1	J0003
33	Bearing, Sealed, 1-1/4" 1654 - 2RS	2	J0060
34	Bearing, Roller, 1.5", 3/8" Bore	6	J0045
35	Upper Gearbox Support Bracket	1	E5356
36	Locking Collar, 1"	1	J0067
37	Pin, Picker, 1/2 x 1-1/2, PLT	1	J1550
38	Washer, Lock, 7/16, PLT, Split	2	J1210
39	Screw, 7/16 - 14, 2" PLT	2	J0718
40	Washer, Flat, 5/16, PLT	3	J1111
41	Nut, Hex, 1/4 -20, PLT, Split	2	J0990
42	Nut, Hex, 3/8 - 16, PLT, Split	7	J1025
43	Nut, Lock, 3/8 -24, PLT, Split	2	J1030
44	Nut, Hex, 7/16 - 14, PLT, Split	2	J1035
45	Screw, 1/4 - 20, 1" PLT	2	J0508
46	Washer, Lock, 1/4", PLT	2	J1195
47	Clip, Hair Pin, .09 x 2"	1	J5410
48	Screw, 3/8 - 16, 1.25", PLT	11	J0616
49	Nut, Jam, 3/8 -16, PLT	4	J1016
50	Chain, #60, 73 Links	1	E5359-01
51	Chain, Connector, #60	1	J1775
52	Key, 1/4" Square x 1"	3	E5315
53	Nut, Hec, 3/8 - 16, PLT	12	J1020
54	Screw, 3/8-16, 1", PLT	12	J0606
55	Washer, 2.5" O.D. x 3/8" I.D., 14 gauge	1	J1140

## GEARBOX COMPONENTS - BOOT 6" & 8"

BOOT  
SWSW0003  
990712JRW

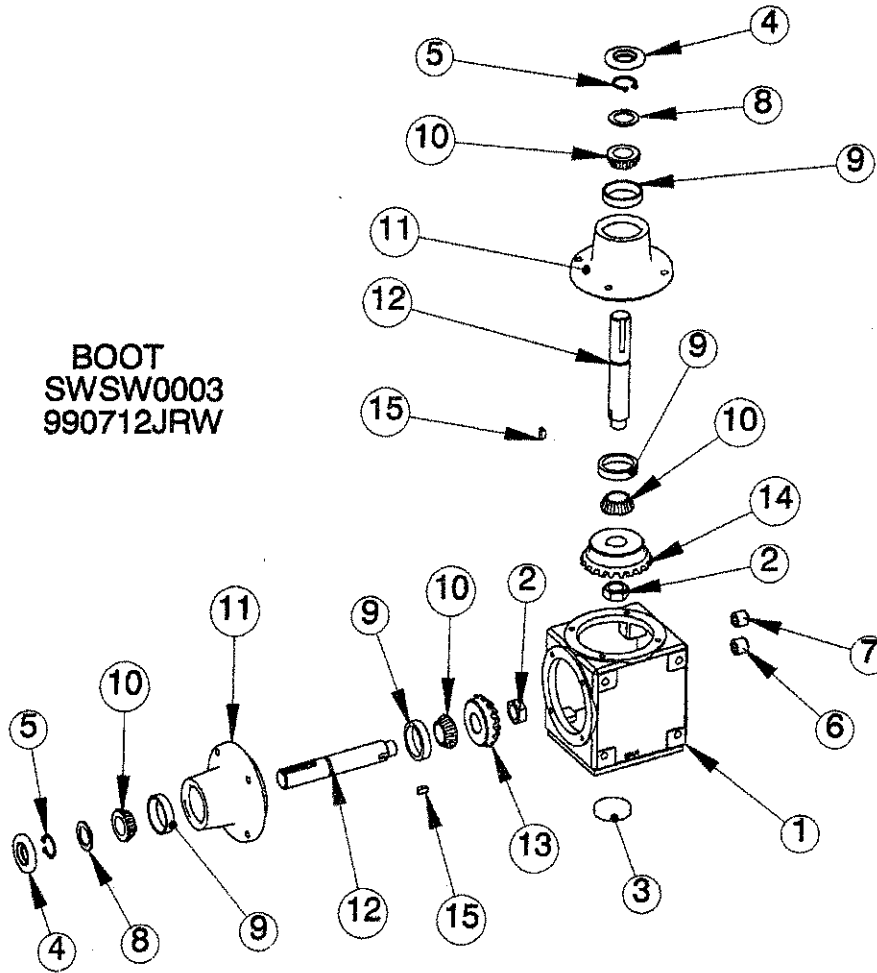

REF. #	DESCRIPTION	QTY	COMP. #
	Gearbox Complete for Boot	(1:1-1/2)	E5822
1	Gearbox Case , Two Hole	1	F9004
2	Nut, Lock, 3/4 - 16, PLT, Thin, Nylon	2	J1055
3	Plug, Soft, 1.875 PC	1	J6980
4	Seal, 1.000 x 2.004, R/C, 10124	2	J6993
5	Snap Ring, 1.00, 329, Eaton	2	J3584
6	Plug, Vented, 1/2, Cntr Sunk Head	1	J2616
7	Plug, 1/2, Hex Center Sunk Head	1	J2615
8	Bushing, Machine, 1-14 Ga, N-Rim	2	J1265
9	Cup, Bearing, L-44610	4	J0105
10	Bearing, 1", Tapered, L-44610	4	J0110
11	Hub, Only, Standard, W/Cup J0105	2	F9007
12	Shaft, 1", Keyway, 6-1/2" long	2	F4738
13	Gear, Small, (14 Teeth)	1	F4740
14	Gear, Bevel, 1" Bore (21 Teeth)	1	F4739
15	Key, Woodruff, 1/4 x 3/4, 9/16" long	2	F4745
16	Plastic shims, between Hub & case .003 thick	As needed	J7090
	Plastic shim, .010 thick	As needed	J70901
17	Screws, 5/16 -18 x1 Gr5 (not shown)	8	J0527
18	Washer, lock, 5/16" (not shown)	8	J1200

# GEARBOX COMPONENTS - SUMP

## 6" & 8"

6" & 8" SUMP  
SWSW0002  
JLD980615

REF. #	DESCRIPTION	QTY	COMP. #
	Complete gearbox, lower sump, 6" & 8"		E5320
	Complete gearbox, sump, upper 6" & 8"		E5325
1	Shaft, 1-3/8" main, lower sump, 6" & 8"	1	E5900
	Shaft, 1-3/8" main, upper sump	1	E5901
2	Open end plate w/grease zerk & cup	1	E59021
3	Hub, Complete, Lower 6" & 8"	1	F9015
	Hub, Complete, Top, 6" & 8"		E5330
	Hub, Only		F9007
4	Seal, 1-3/8"	1	J7010
5	1" Keyway shaft x 6-1/2" (lower)	1	F4738
	Shaft, 1" (upper) 8" long	1	E5903
	Shaft, 1" threaded (upper) Prior 1988	1	E5906
6	Machine bushing, 1-3/8", 10 Ga	1	J1275
7	Bearing, 14137A	1	J0120
8	Bearing, 02875	1	J0130
9	Bearing, L44643	2	J0110
10	Bearing cup, L44610	2	J0105
11	Bearing cup, 02820	1	J0125
12	Bearing cup, 14276	1	J0115
13	Machine bushing, 1", 14 Ga	1	J1265
14	Elbow, Street, 1/2 x 90 degrees, upper sump	1	J2520
15	Lock nut, 3/4" - 16 thin nylon	1	J1055
16	Gear, 21 teeth 1-1/4" bore	1	F4742
17	Gear, 14 teeth	1	F4740
18	Snap ring, 1"	1	J3584
20	Gearbox case, Complete w/grease zerk	1	F90041
	Gearbox case only		F9004
21	Grease zerk	1	J3605
22	Seal, 1"	1	J6993
23	Soft plug, 1-7/8"	1	J6980
24	Woodruff key, hard	2	J3600
24A	Key, 1/4 x 3/4 x 9/16" long	2	F4745
25	Plug, black, 1/2"	1	J2615
26	Plug vented, 1/2" center sink head	1	J2616
27	Plastic shims, .003 thick (use amount as needed)	3-5	J7090
	Plastic shims, .010 thick	5	J70901
28	Snap ring, 1-3/8"	1	J3589
29	Screw, 5/16-18 x 1" GR5 (not shown)	6	J0527
30	Screw, 5/16-18 x 1.25 Gr 5 (not shown)	2	J0550
31	Washer, Lock, 5/16 (not shown)	8	J1200

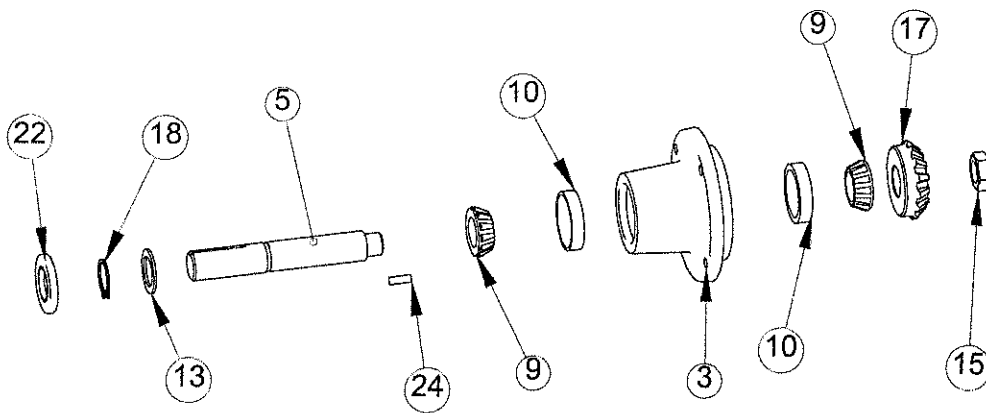
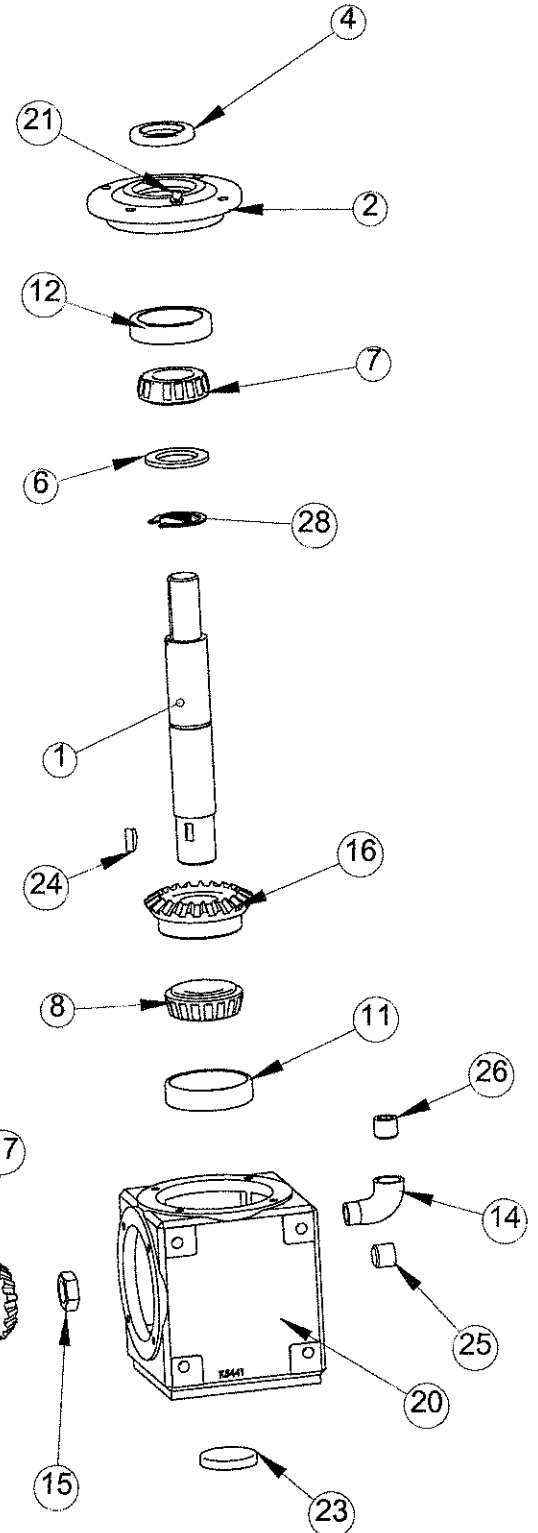

# 10" SWEEPWAY TOP GEARBOX

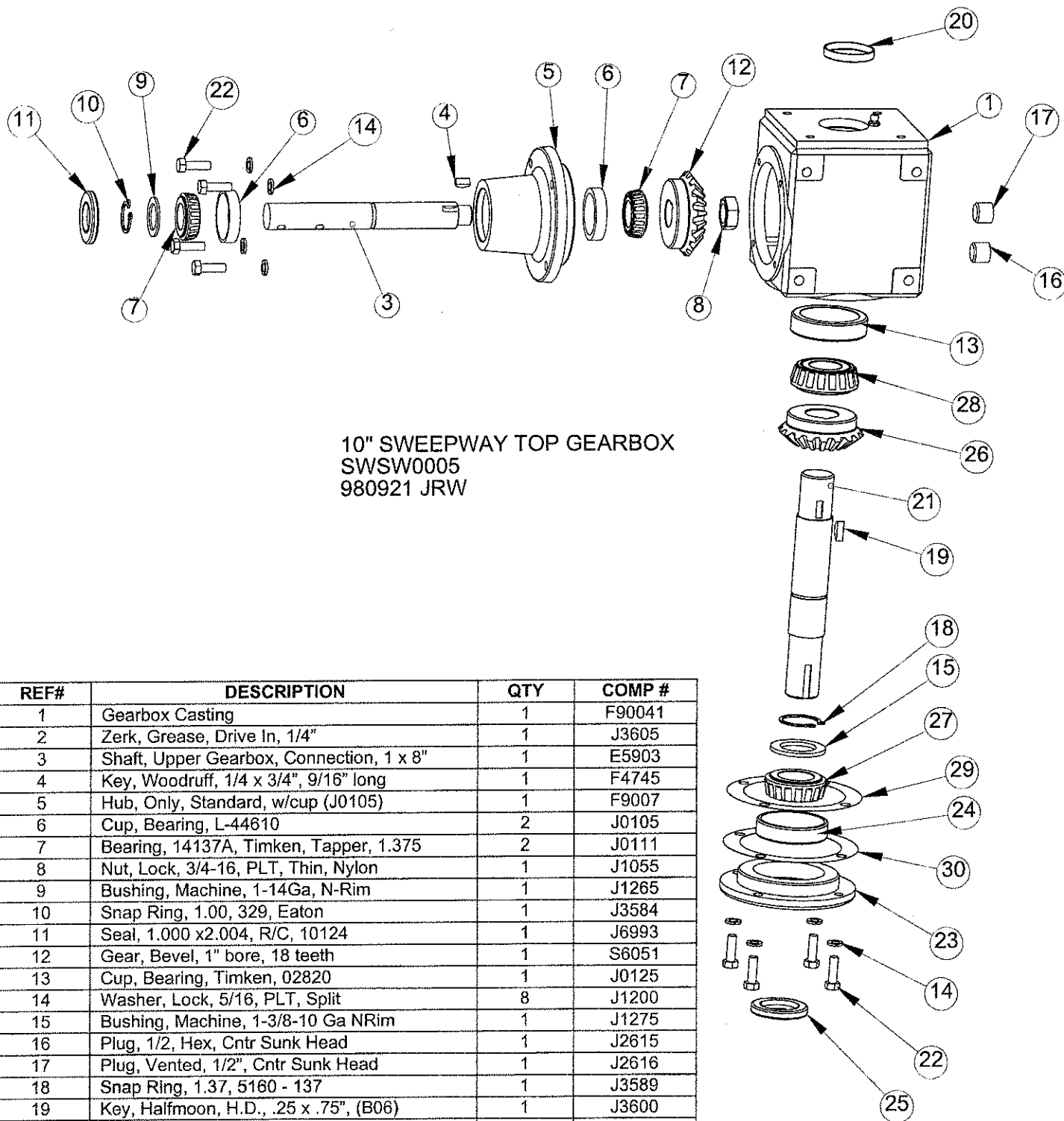

10" SWEEPWAY TOP GEARBOX  
SWSW0005  
980921 JRW

REF#	DESCRIPTION	QTY	COMP #
1	Gearbox Casting	1	F90041
2	Zerk, Grease, Drive In, 1/4"	1	J3605
3	Shaft, Upper Gearbox, Connection, 1 x 8"	1	E5903
4	Key, Woodruff, 1/4 x 3/4", 9/16" long	1	F4745
5	Hub, Only, Standard, w/cup (J0105)	1	F9007
6	Cup, Bearing, L-44610	2	J0105
7	Bearing, 14137A, Timken, Tapper, 1.375	2	J0111
8	Nut, Lock, 3/4-16, PLT, Thin, Nylon	1	J1055
9	Bushing, Machine, 1-14Ga, N-Rim	1	J1265
10	Snap Ring, 1.00, 329, Eaton	1	J3584
11	Seal, 1.000 x 2.004, R/C, 10124	1	J6993
12	Gear, Bevel, 1" bore, 18 teeth	1	S6051
13	Cup, Bearing, Timken, 02820	1	J0125
14	Washer, Lock, 5/16, PLT, Split	8	J1200
15	Bushing, Machine, 1-3/8-10 Ga NRim	1	J1275
16	Plug, 1/2, Hex, Cntr Sunk Head	1	J2615
17	Plug, Vented, 1/2", Cntr Sunk Head	1	J2616
18	Snap Ring, 1.37, 5160 - 137	1	J3589
19	Key, Halfmoon, H.D., .25 x .75", (B06)	1	J3600
20	Soft Plug, 1.875 PC	1	J6980
21	Shaft, 8-3/4", 1-3/8" W/Keyway	1	E5369
22	Screw, 5/16 - 18, 1", PLT, Gr 5, HHCS	8	J0527
23	Plate, Open End	1	E5902-01
24	Cup, 2-23/32 O.D. 14276	1	J0115
25	Seal, 1.375 x 2.129, R/C, 13650	1	J7010
26	Gear, Bevel, 1-1/4" Bore, 18 teeth	1	E5372
27	Bearing, 14137 A, Timken, Tappered, 1.375	1	J0120
28	Bearing, 1.25, .94 Tappered, 02875	1	J0130
29	Shim, 3.88 x 5.12 x 0.003 (as needed)	1	J7090
30	Shim, 3.88 x 5.12 x 0.010 (as needed)	1	J70901

# 10" SWEEPWAY LOWER GEARBOX

REF. #	DESCRIPTION	QTY	COMP. #
1	Casting, BTM Gearbox, H. D. 3 hole	1	F9051
2	End Plate, closed, H. D. 1-3/8" FSTD	1	F9061
3	Casting, Hub, H.D. 1-3/8", 10" 1998	1	E5365
4	Shaft, Gearbox	1	E5366
5	Gear Blank ,27 tooth, 1-3/8" Bore	1	F9053
6	Shaft, 8-5/16"	1	E5367
7	Gear Blank, 18 tooth Bevel, 1-1/4" bore	1	F9052
8	Casting, Gearbox, Hub, H.D. 1-3/8" w/cup(J0115)	1	F9065
9	Cup, 2-23/32 O.D. 14276	3	J0115
10	Nut, Lock, 1-1/8-12 PLT Thin Nylon	1	J1067
11	Bushing, Machine, 1-3/8-10 Ga. N. Rim	1	J1275
12	Snap Ring, 1.37, 5160-137	1	J3589
13	Bearing, 14137A, Timken, Tappered, 1.375	3	J0120
14	Key, Halfmoon, .25 x 1.25 (810) #21	2	J3604
15	Seal, 1.38 I.D. N, 472658	2	J7061
16	Shim, 4.625 x 6.010 x 0.003 (As needed)	6	J7085
17	Bearing, 1.375 I.D., 3872 Timken	1	J0027
18	Cup, 3.375 O.D. 3820, 3821, Timken	1	J0028
19	Elbow, Street, 1/2", 90° Sch 40	1	J2520
20	Plug, 1/2, Hex Center, Sunk Head	2	J2615
21	Screw, 3/8-24, 1" PLT, Gr 5	18	J0612

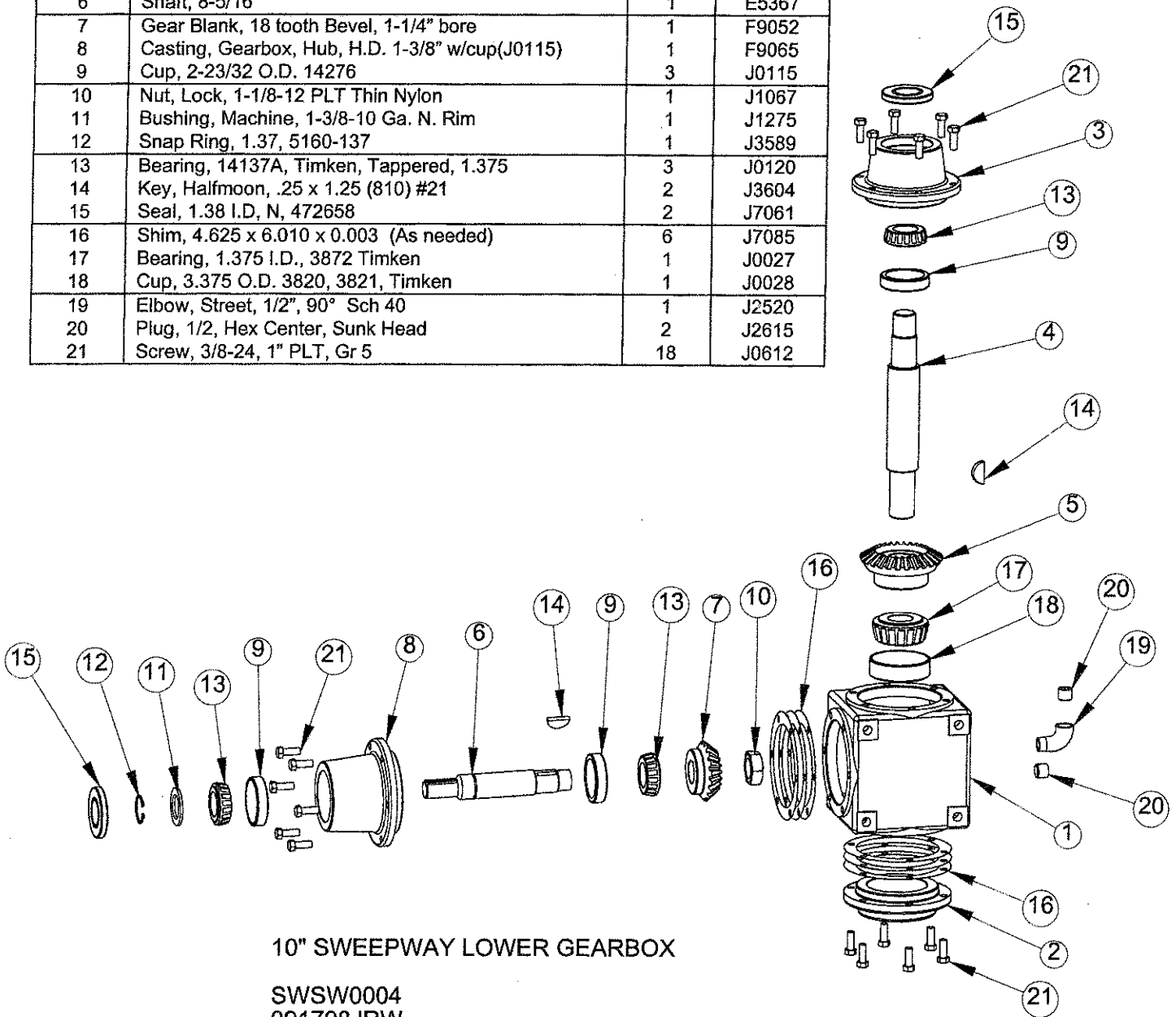

10" SWEEPWAY LOWER GEARBOX

SWSW0004  
091798JRW

